



Australian Government

Bureau of Meteorology

Assimilation of Level-1D ATOVS Radiances in Australian Regional and Mesoscale Data Assimilation and Prediction Systems

**C.Tingwell, M. Chattopadhyay, C. Vincent, B. Harris, P. Steinle
and W. Bourke**

**Bureau of Meteorology Research Centre
Bureau of Meteorology
Melbourne, Australia**



Outline

- Current ATOVS assimilation trials in Bureau global NWP system (GASP)
[B. Harris]
- DB ATOVS data
- Regional and mesoscale assimilation of ATOVS data (LAPS and WLAPS)



L60 GASP

- Brett Harris

- T239/L60
- Assimilating HIRS/AMSU-A/AMSU-B
- NOAA-15,16,17,18
- AMSU-A from AQUA
- Radiances processed to level 1D supplied by Met Office
- 1DVAR → GenSI Analysis
- Thinning algorithm will choose sounding with highest information content within a given radius to achieve significant reductions in analysis time without loss of forecast skill
- Pre-operational trials soon

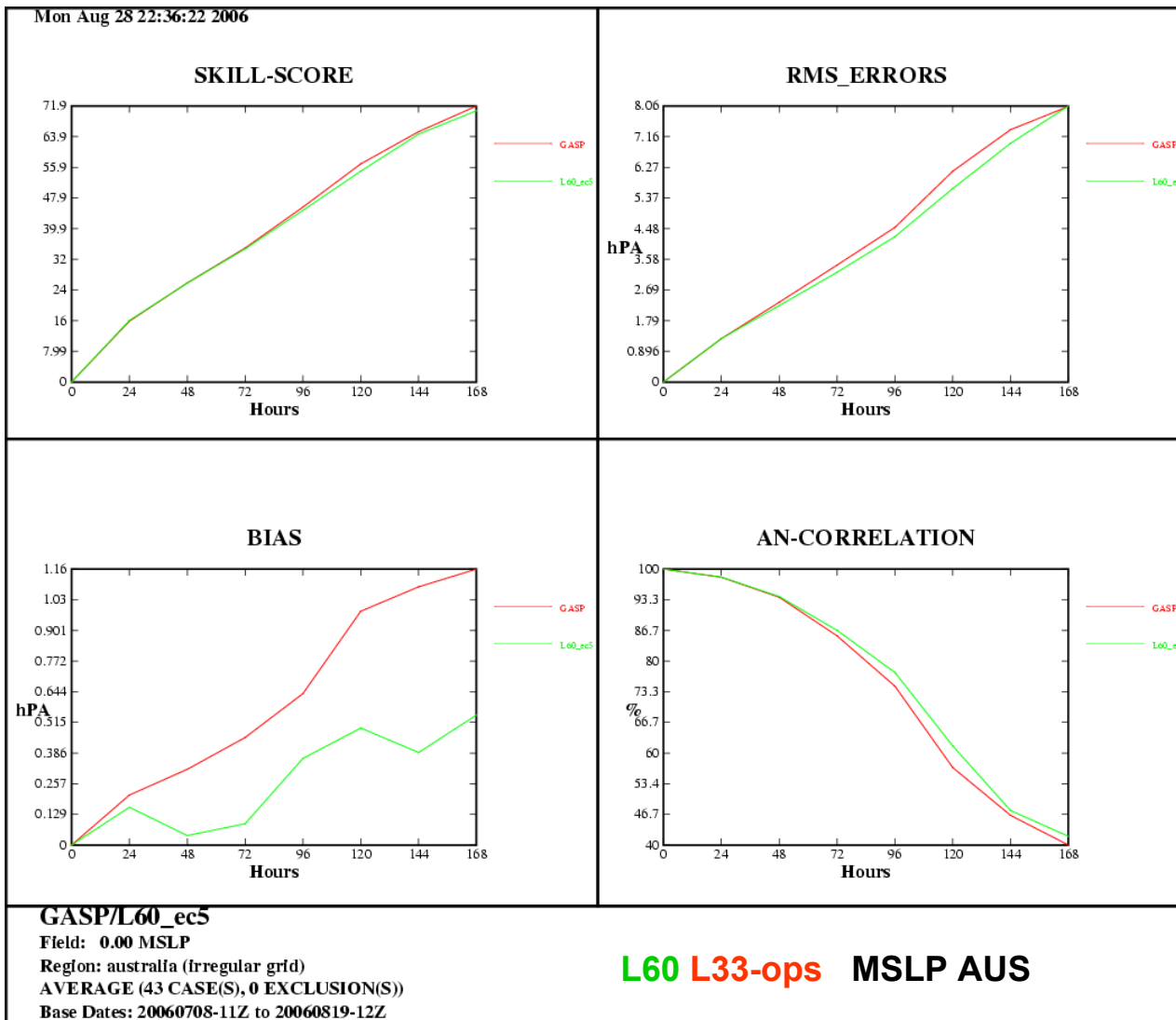

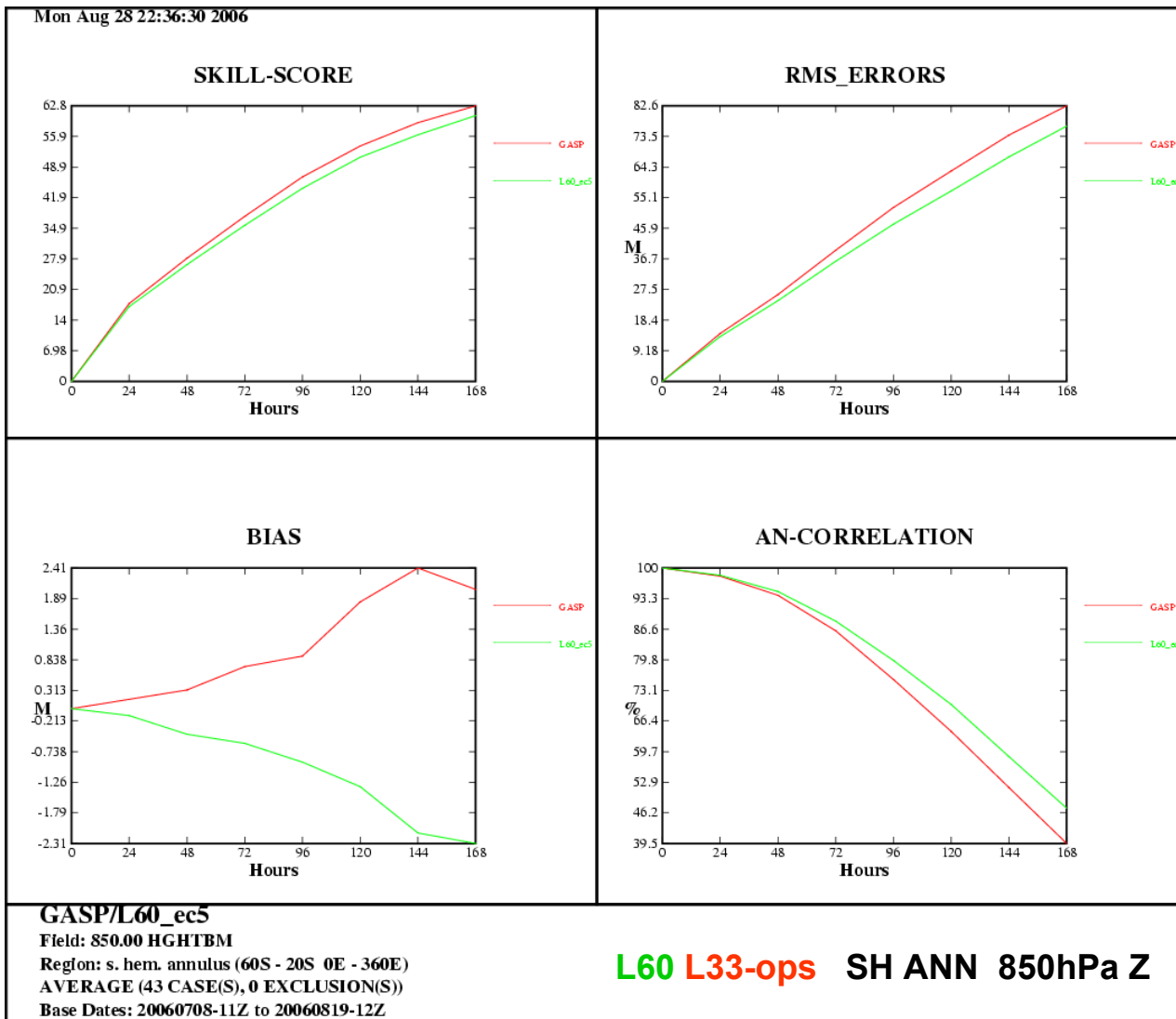

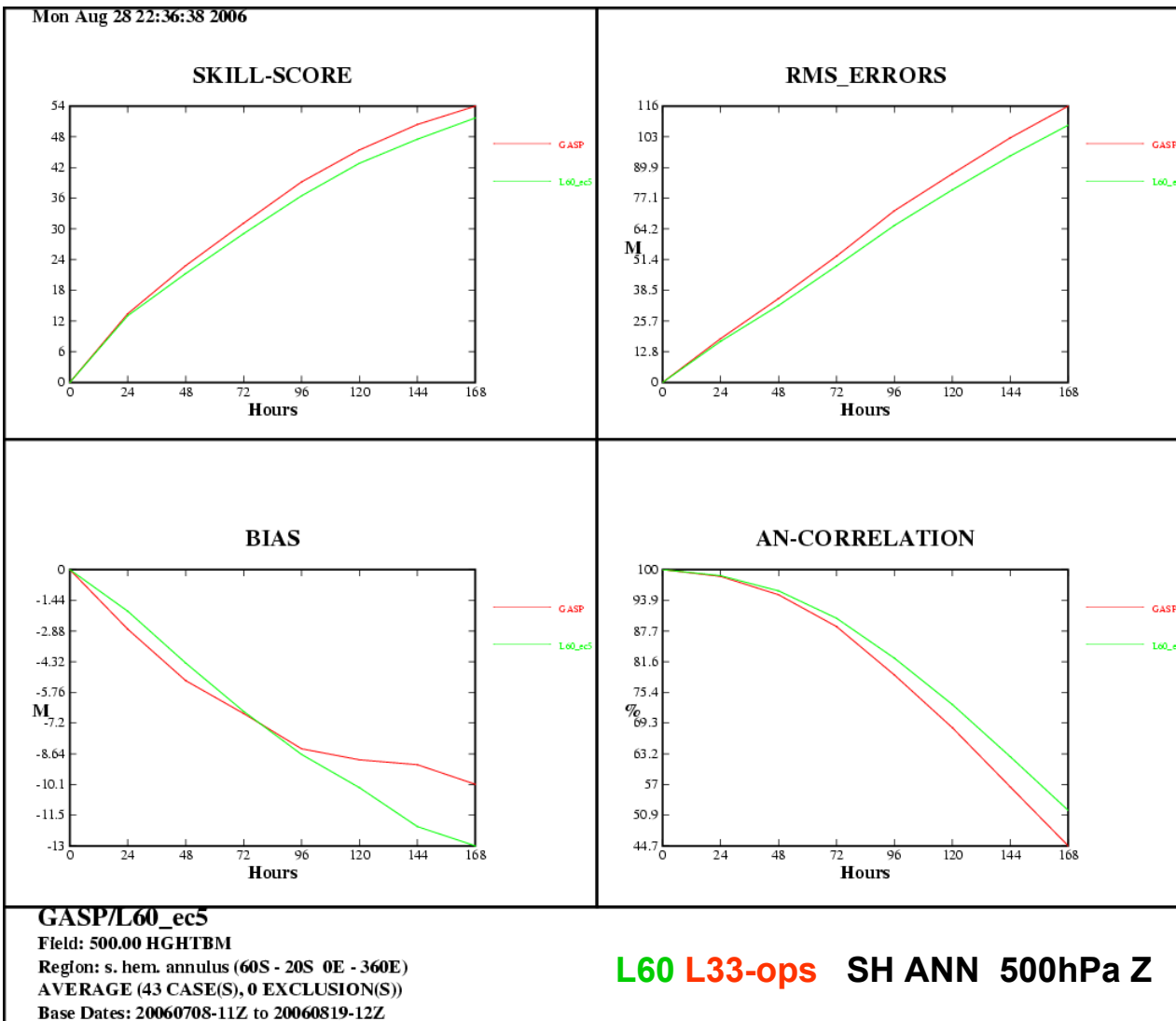

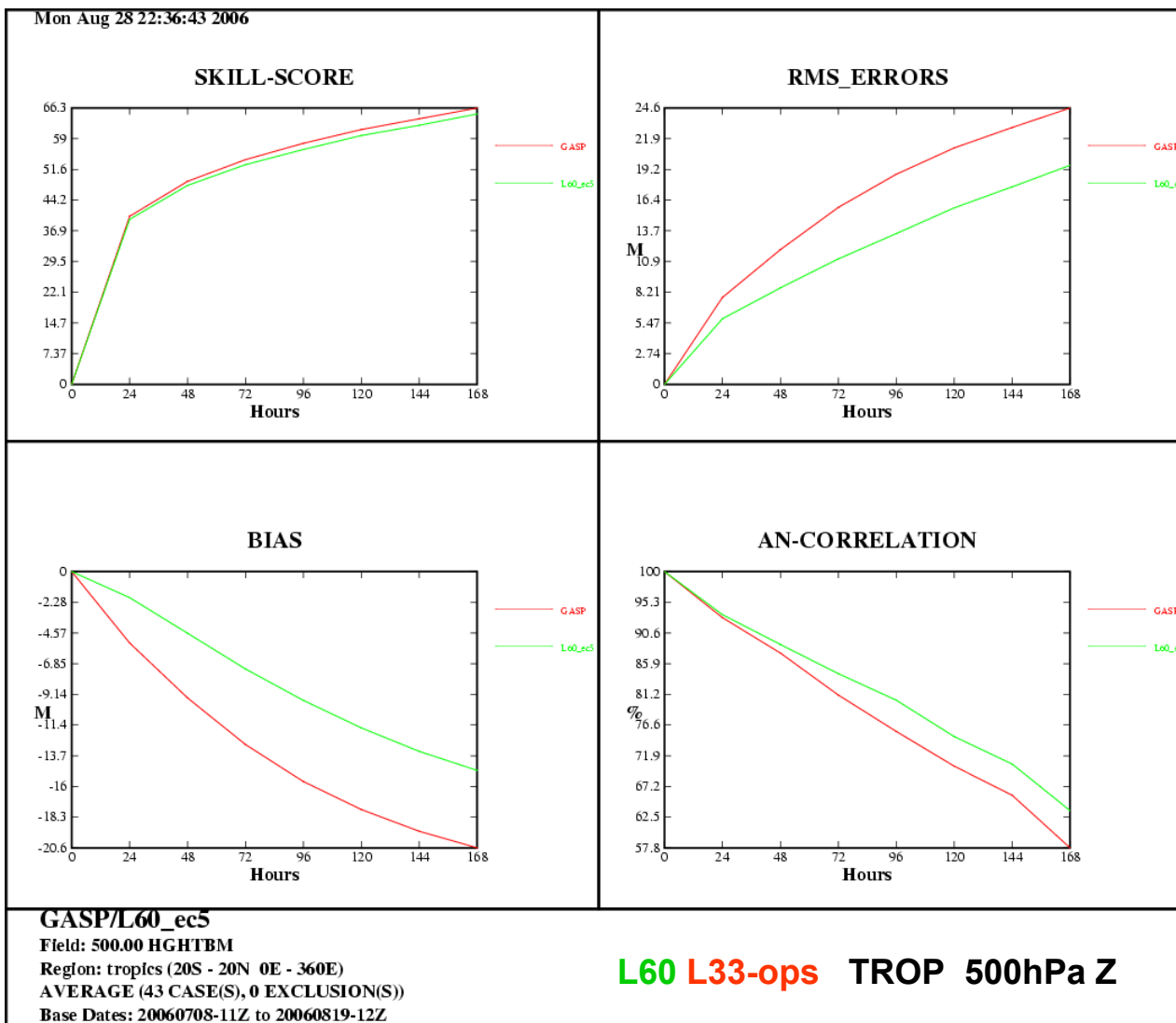



ATOVS Radiance Handling and Assimilation

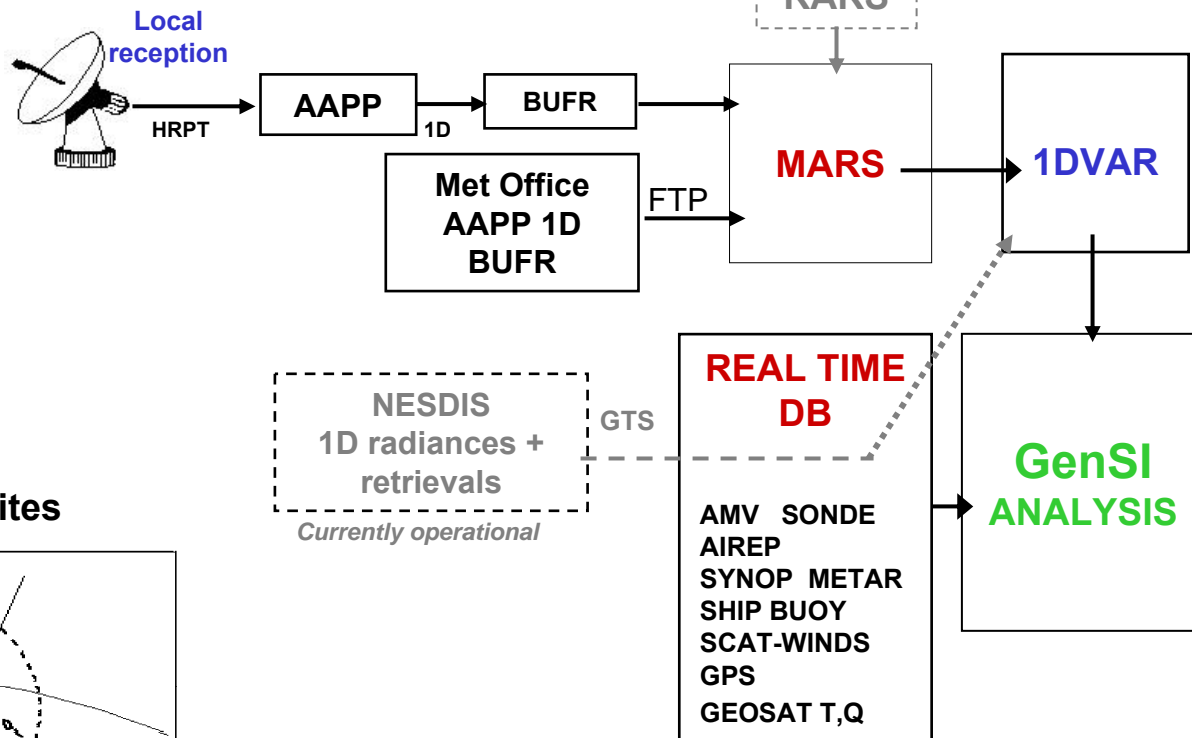

Australian HRPT Reception sites

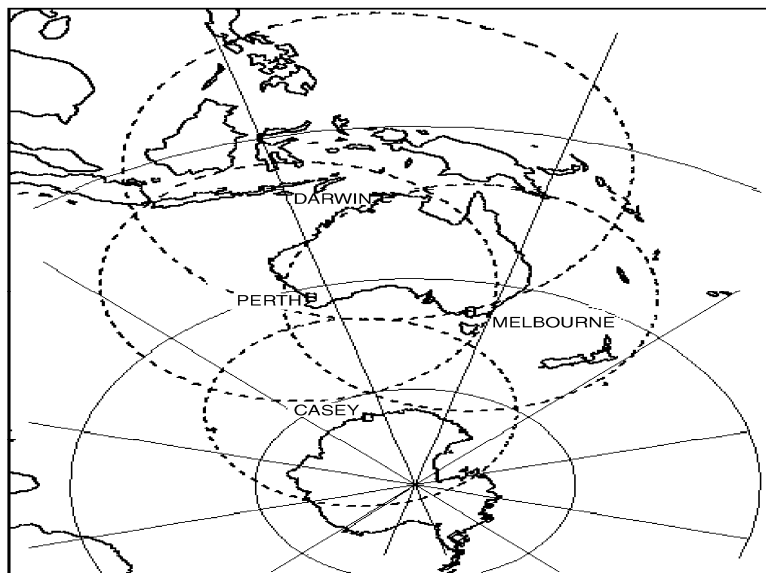

Satellites: NOAA-15,16,17,18, (AQUA Met Office only)
Instruments: HIRS, AMSU-A, AMSU-B, MHS

Operational requirements for timely forecasts compel early data cut-offs for basedate-time analyses. Locally received and processed ATOVS data (top row) fill in the gaps in the global ATOVS data set supplied by the Met Office (bottom row) caused by the early cut off.

It is hoped that in the near future data from the Regional ATOVS Retransmission Service (RARS) will also be used. Tests with radiances supplied by JMA should start soon.

LOCAL

12Z

00Z

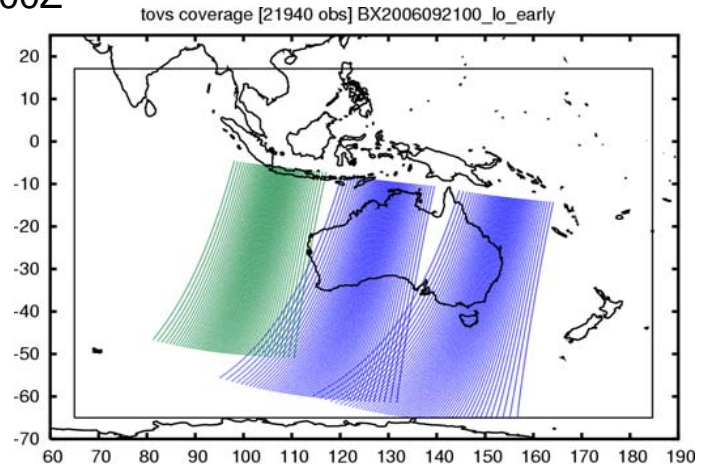
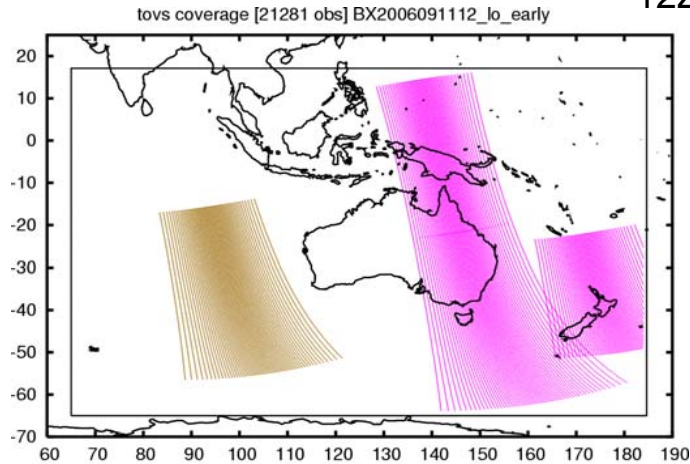

GLOBAL

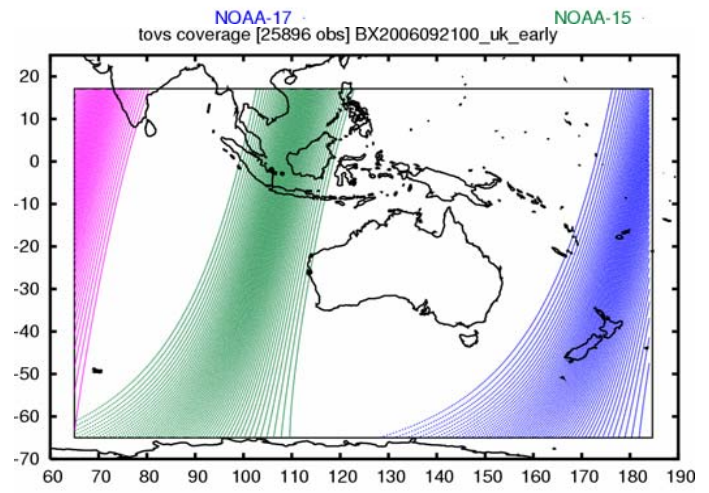
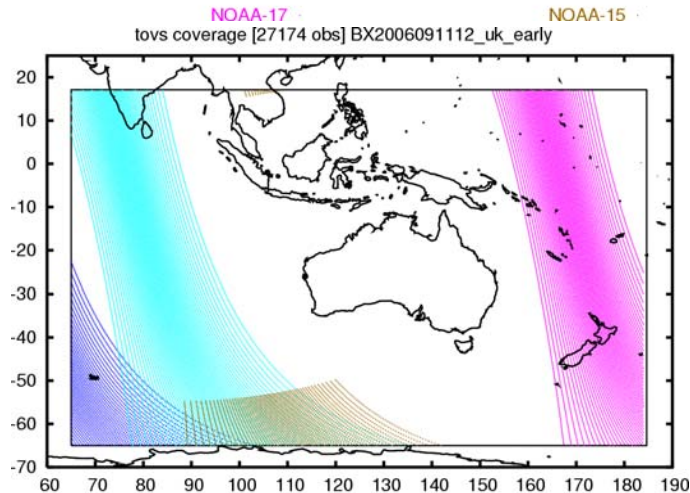

NOAA-18 · NOAA-17 · NOAA-16 · NOAA-15

NOAA-17 · NOAA-16 · NOAA-15

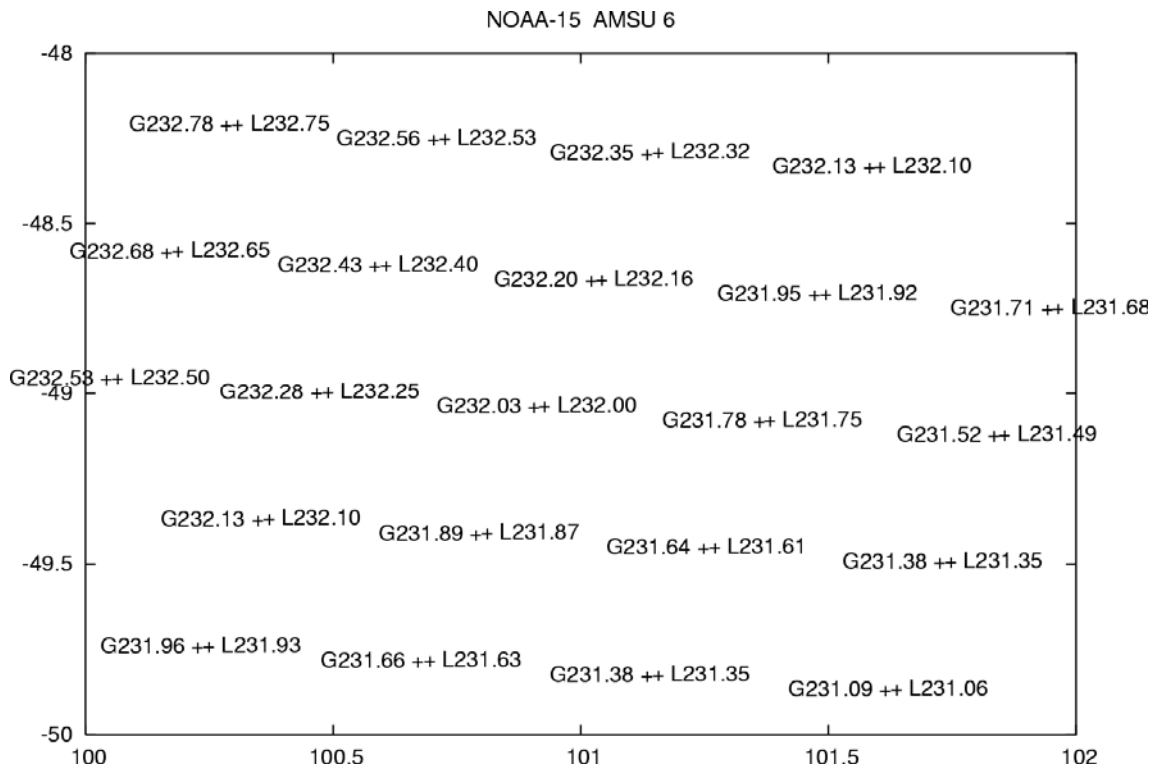

Comparison plots (excerpt at left) of ID radiances from UK global set (G) and locally received and processed 1D radiances (L) show generally strong agreement for ATOVS channels used in 1DVAR



LAPS and Wind-LAPS (WLAPS)

WLAPS development has been supported by the Australian Wind Energy Forecasting Capability (AWEFC) initiative



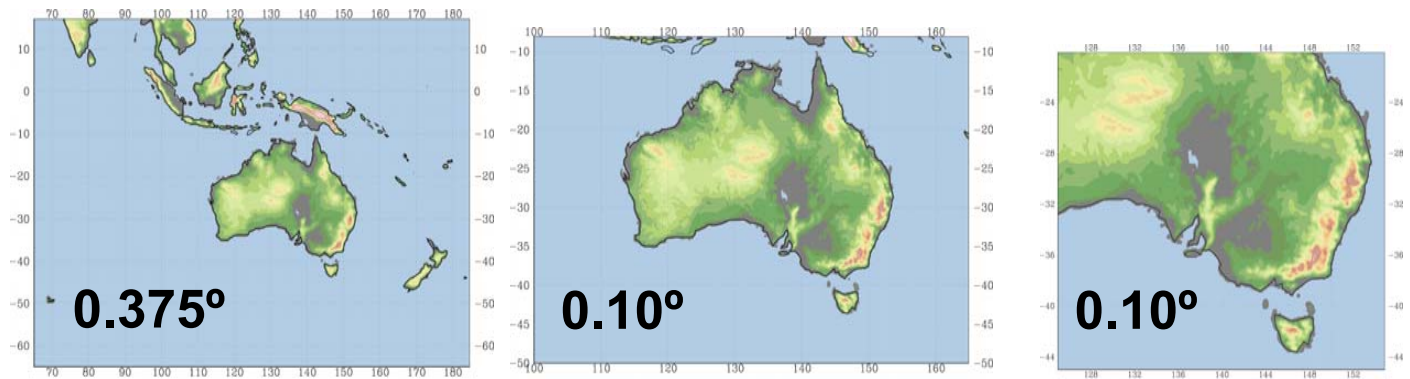

LAPS domain (left), **WLAPS** Australian domain (centre) and SE Aust domain (right)

Comparison of the topography used in LAPS (left) and WLAPS (right) for SE Australia

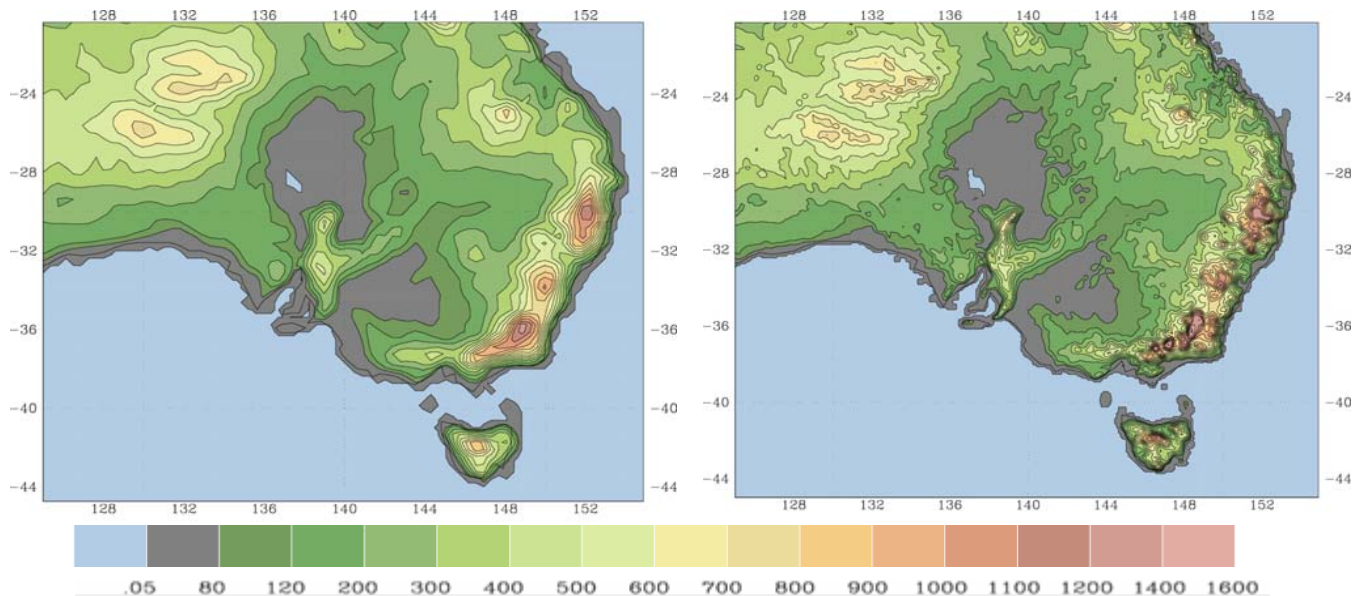



Australian Region LAPS

0.375° grid 61 vertical levels (L61)
Nests in L60 Global system
(**GASP**)
GenSI assimilation, 1DVAR ATOVS
Digital Filter initialisation

Wind-LAPS (WLAPS)

0.10° (10km) grid 61 vertical levels (L61)
Nests in L61 **LAPS**
Full GenSI assimilation including
1DVAR ATOVS
No initialisation.

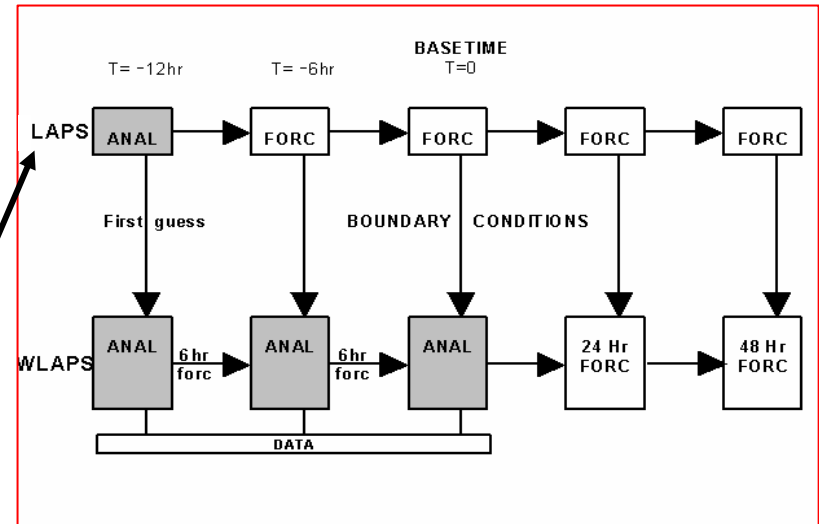
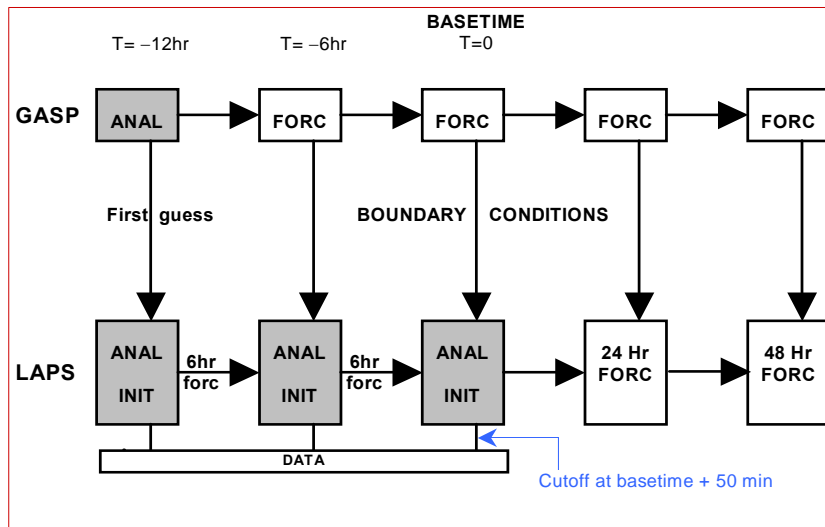

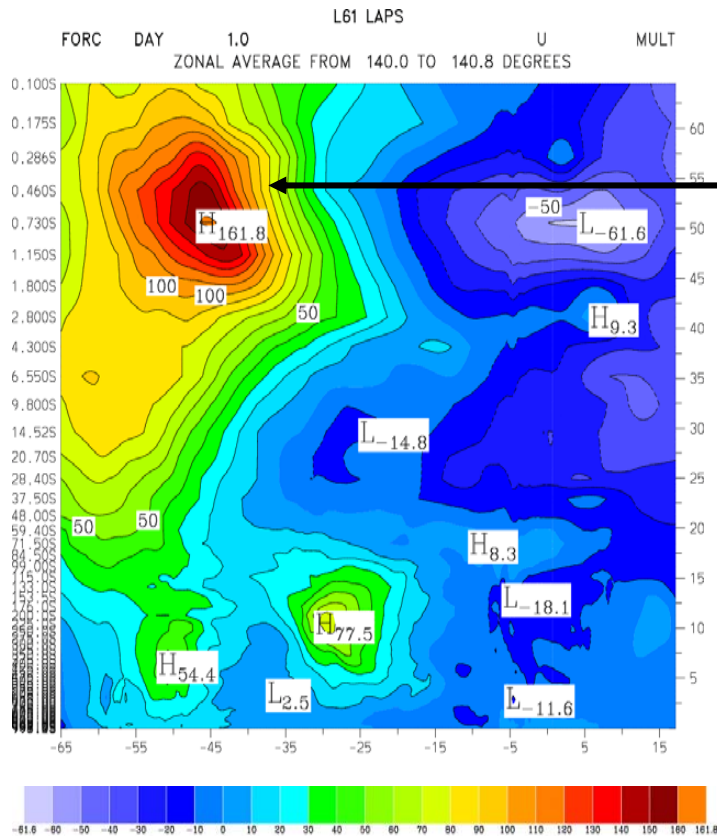

A major issue in producing robust L61 implementations of LAPS and WLAPS has been numerical instability associated with the strong Polar stratospheric jet that develops in the southern part of the Australian region domain in SH winter. Model wind speeds can reach 170 m/s.

Solution

Rayleigh friction is applied at the top of the atmosphere by adding the damping equation

$$\frac{df}{dt} = -K.(f - F)$$

where f is any of the primary dynamical fields U, V, T or q and F is the external nesting field. The damping coefficient has a maximum value at the top of the model and then reduces linearly with sigma level and cuts out at 100 hPa.

L61 LAPS verification

Forecast verification of L61 LAPS continues to show substantial gains over the current operational version of LAPS

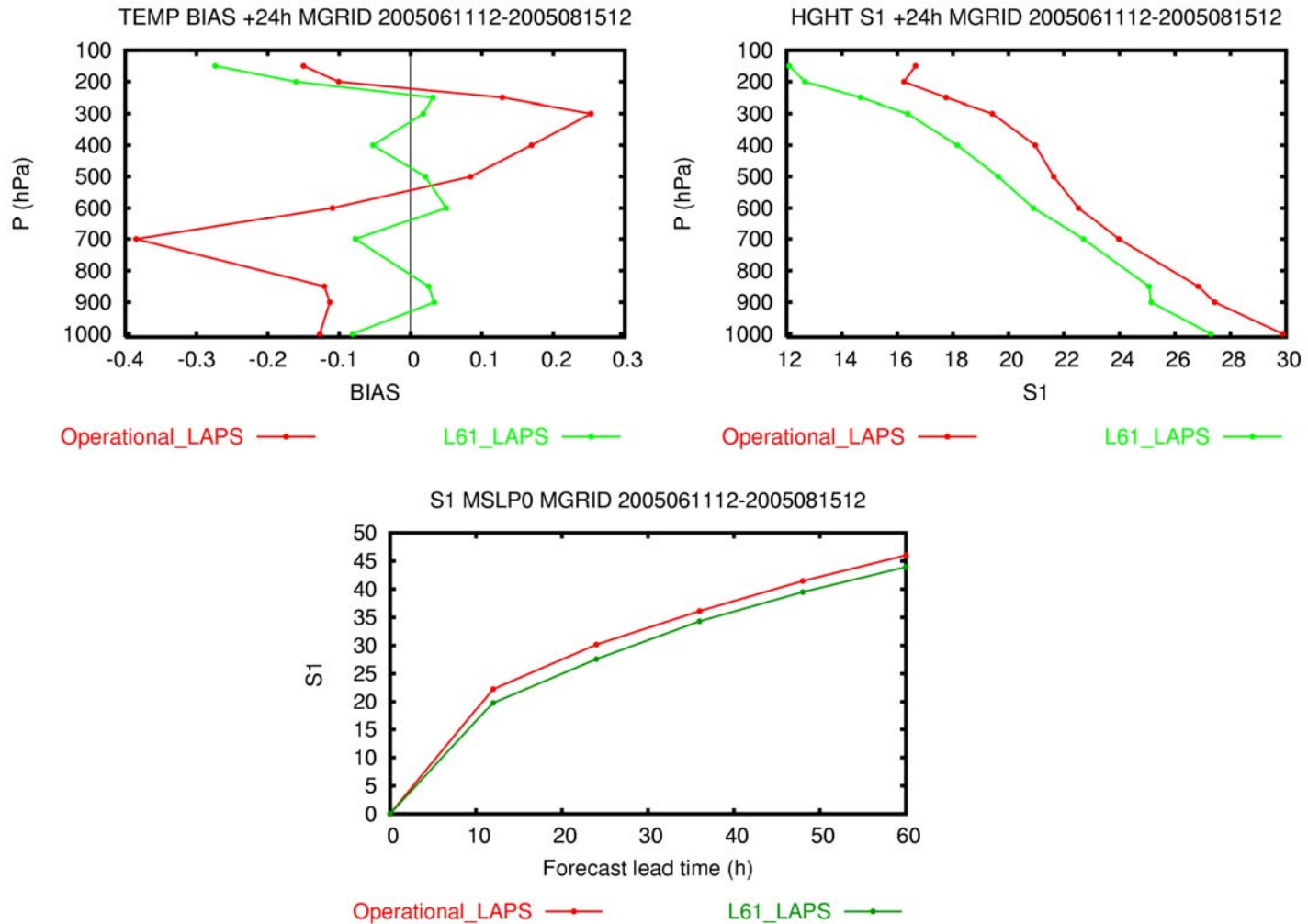



Substantial contributions to the gain in forecast skill at the surface come from improved handling of cyclonic development. The example below shows the 24 hour forecast for the same period from L61 LAPS (left) and operational LAPS (right) with the verifying analysis below.

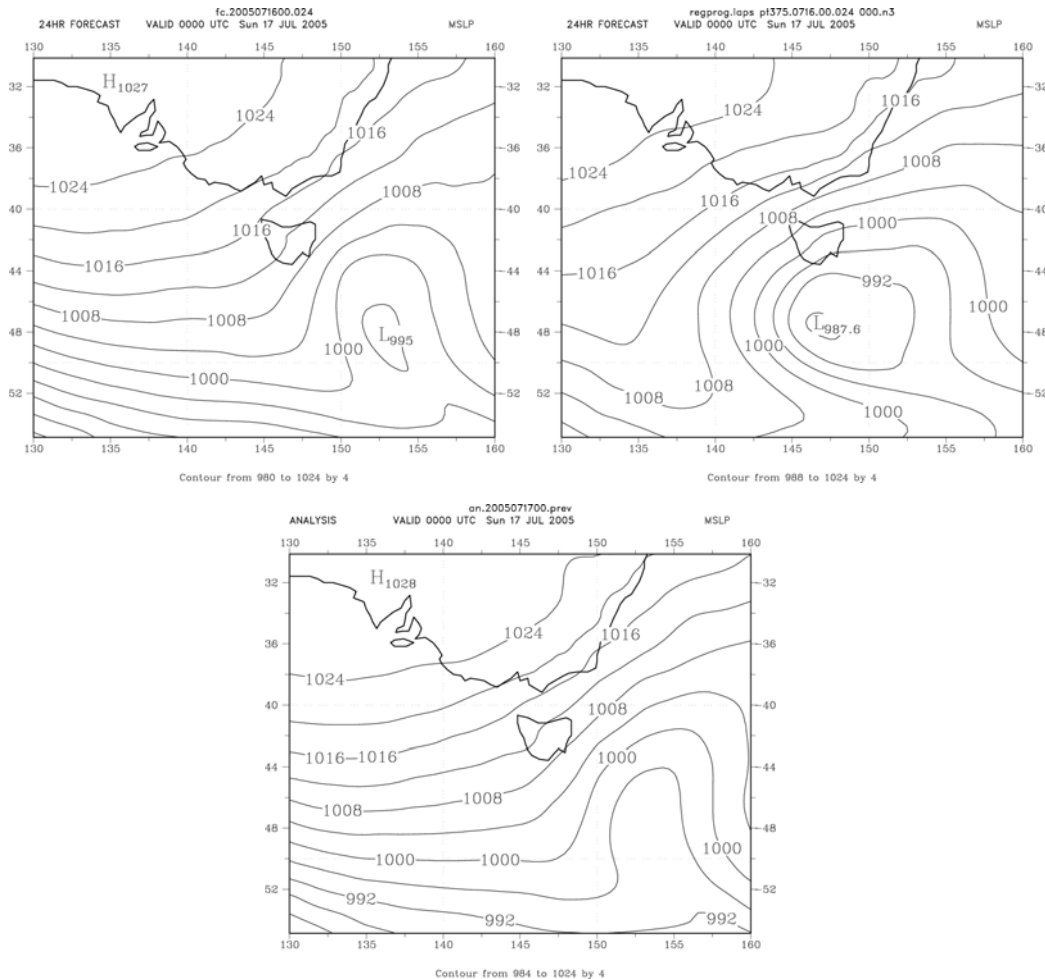

WLAPS gridded winds are physically downscaled to observation location (eg 10m or hub height) and verified against Bureau wind data or wind data supplied from operational wind farms. Statistical downscaling techniques have been used to reduce forecast bias.

In the comparisons that follow, WLAPS is compared to the Bureau's currently operational mesoLAPS (MLAPS) which is run over a 12km grid. MLAPS is initialised from interpolated operational LAPS analyses.

Research WLAPS	Operational MesoLAPS
10km resolution	12.5 km resolution
Own data assimilation at 10 km resolution -utilising AAPP processed radiances	Initialised from interpolated LAPS 37.5 km analysis -utilising NESDIS radiances
61 levels	29 levels
Nested in 61/60 level LAPS/GASP	Nested in Operational LAPS/GASP



Australian Government
Bureau of Meteorology

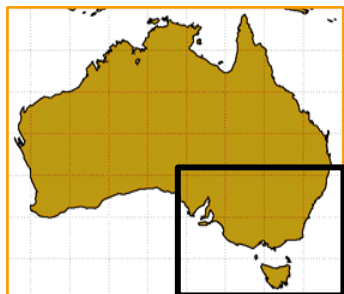

WLAPS

10 m wind speed
Analysis 00UTC 16 July

mesoLAPS

10 m wind speed
Analysis 00UTC 16 July

Improvement in Analysis

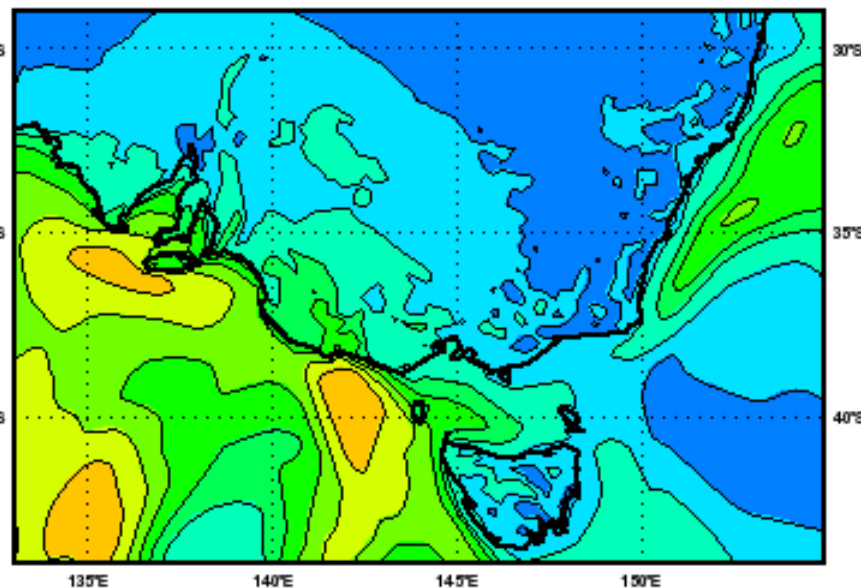
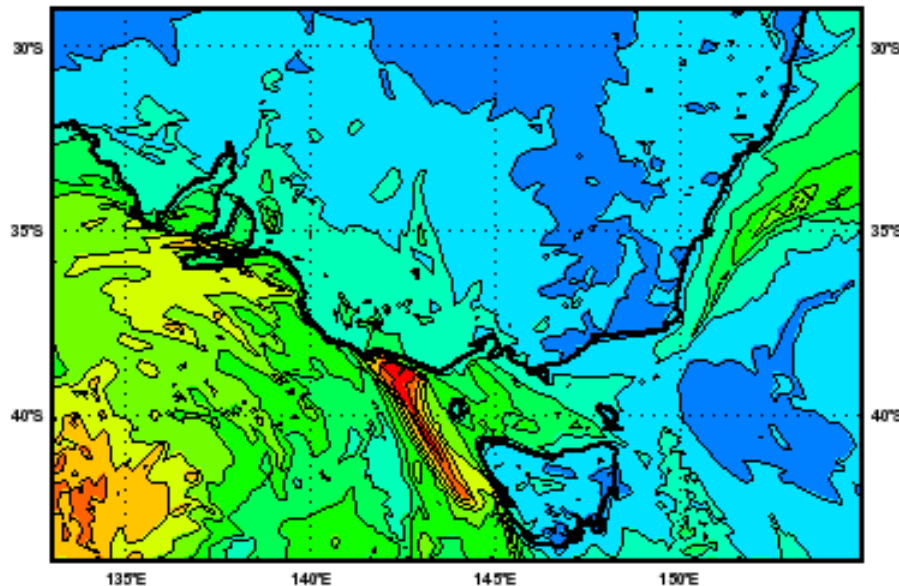



Australian Government
Bureau of Meteorology

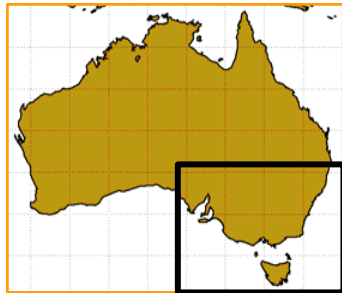

Improvement in timing and amplitude of forecast

WLAPS

10 m wind speed 24 hour
forecast for 00UTC 16 July

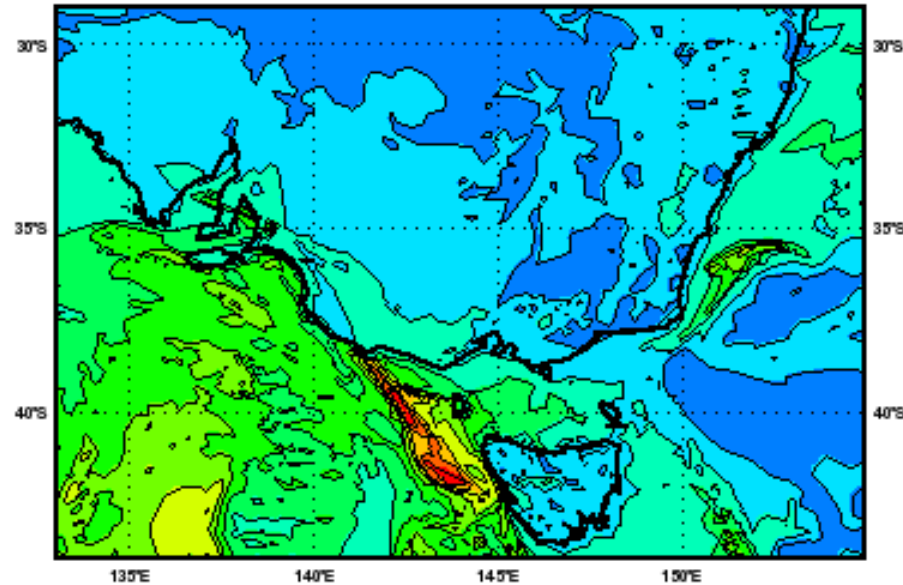

mesoLAPS

10 m wind speed 24 hour
forecast 00UTC 16 July

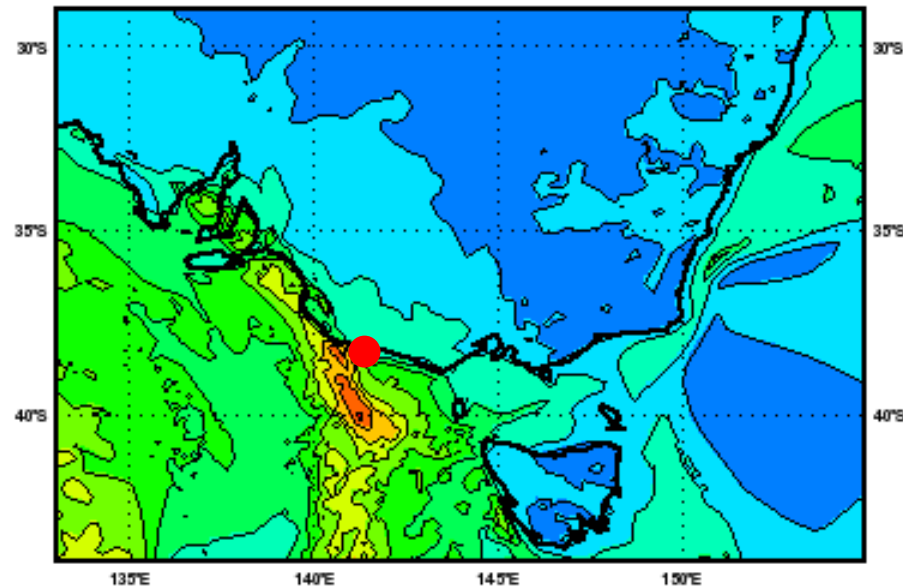

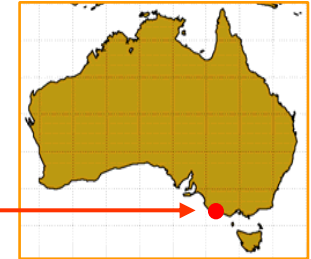

Observed and Forecast 10m wind speed at Cashmore Airport (Portland)

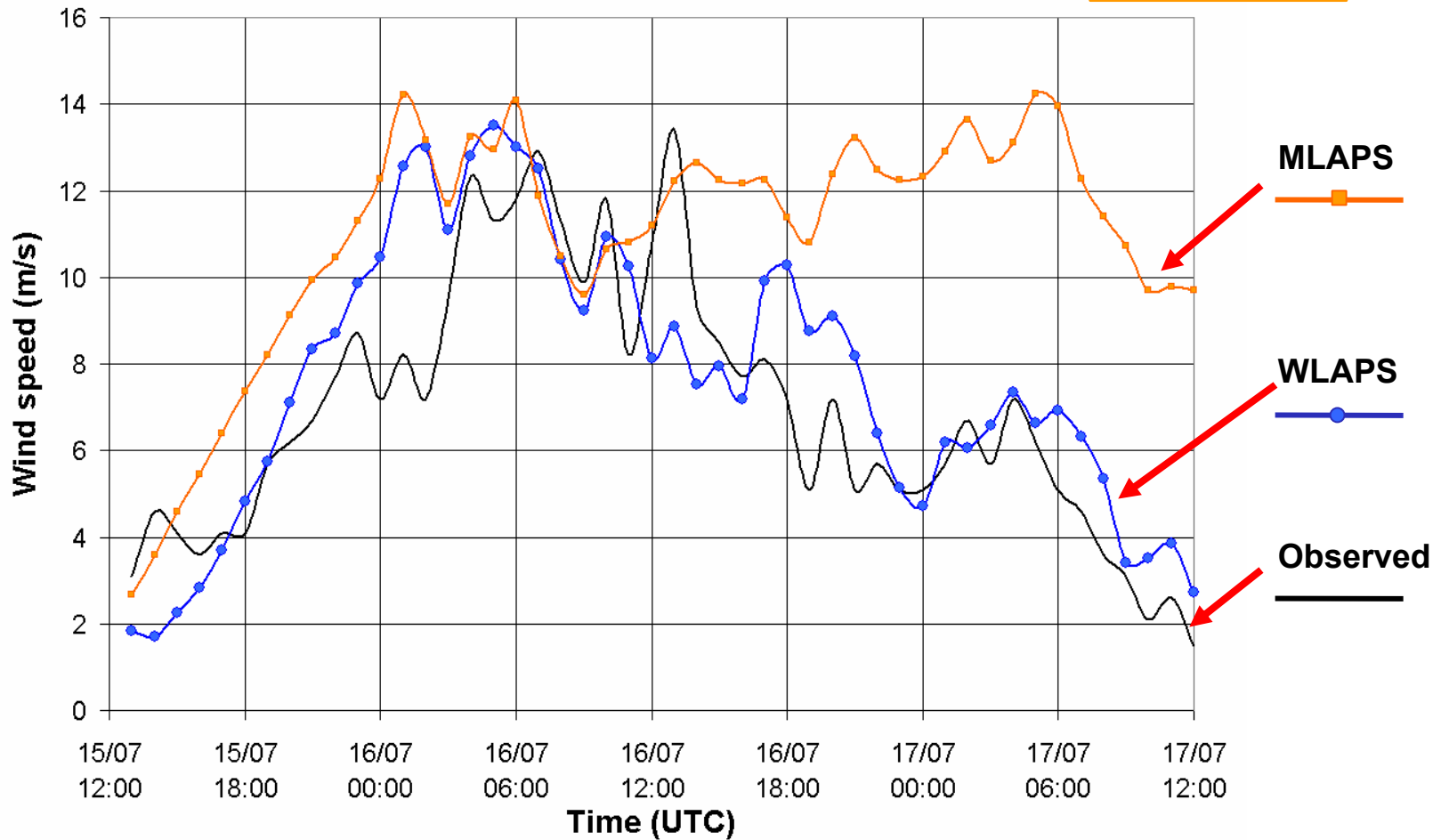



Performance Scores: RMSE and BIAS

- Compare gridded forecasts with gridded analyses.
- Assume analyses are a good proxy for the truth.
- Can penalise high resolution forecasts



24 Hour Forecasts

RMSE
(m/s)

RMSE in 10m Windspeed 24 hour forecast: 6th July to 4th August 2005

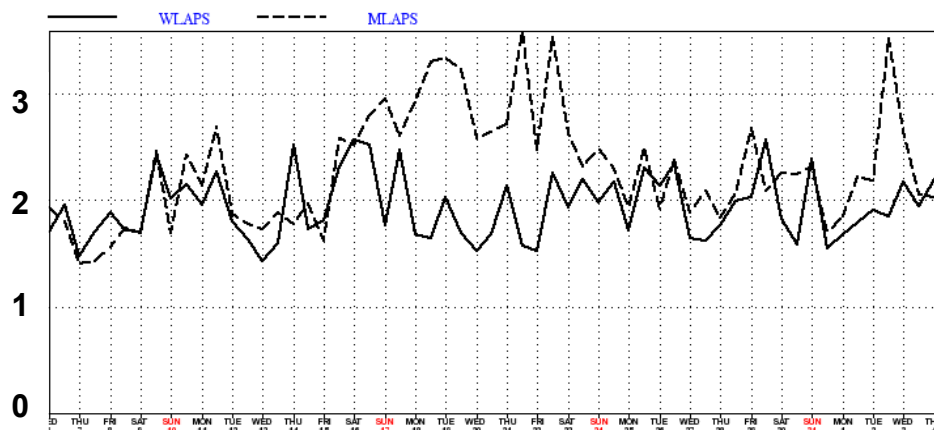

mesoLAPS



WLAPS



BIAS
(m/s)

BIAS in 10m Windspeed 24 hour forecast: 6th July to 4th August 2005

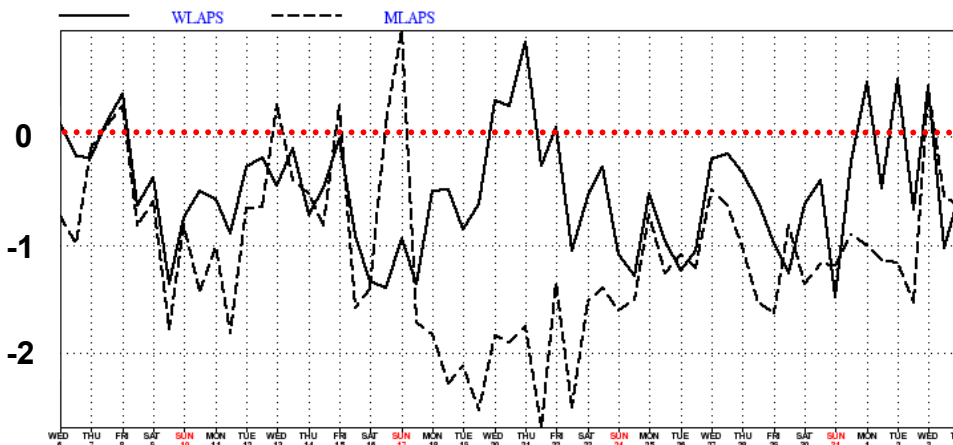



36 Hour forecasts

RMSE
(m/s)

RMSE in 10m Windspeed 36 hour forecast: 6th July to 4th August 2005

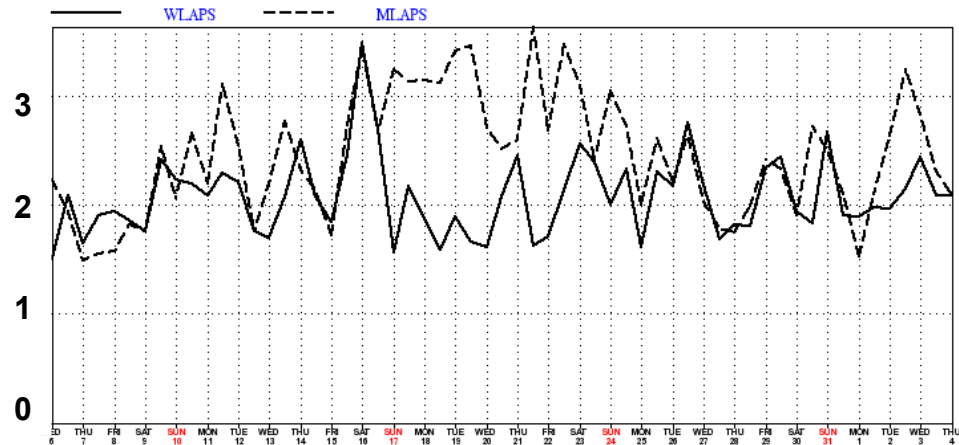

mesoLAPS



WLAPS



BIAS
(m/s)

BIAS in 10m Windspeed 24 hour forecast: 6th July to 4th August 2005

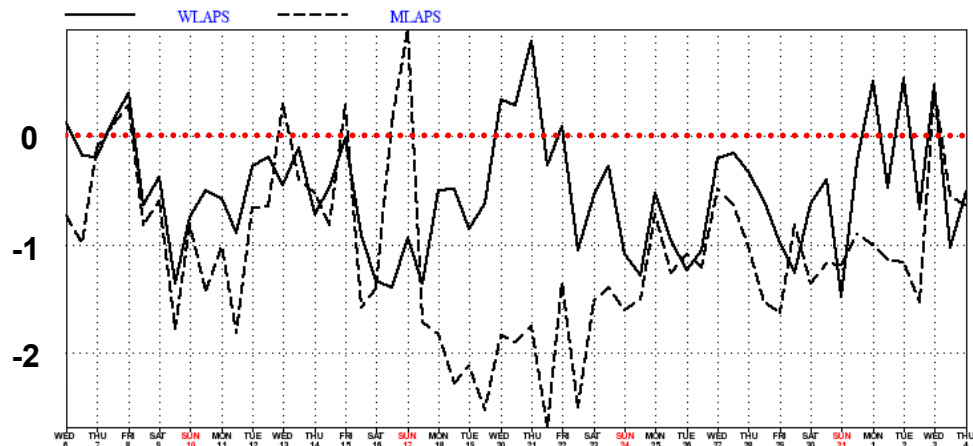

Forecast and observed hub-height windspeed: Eastern Ranges

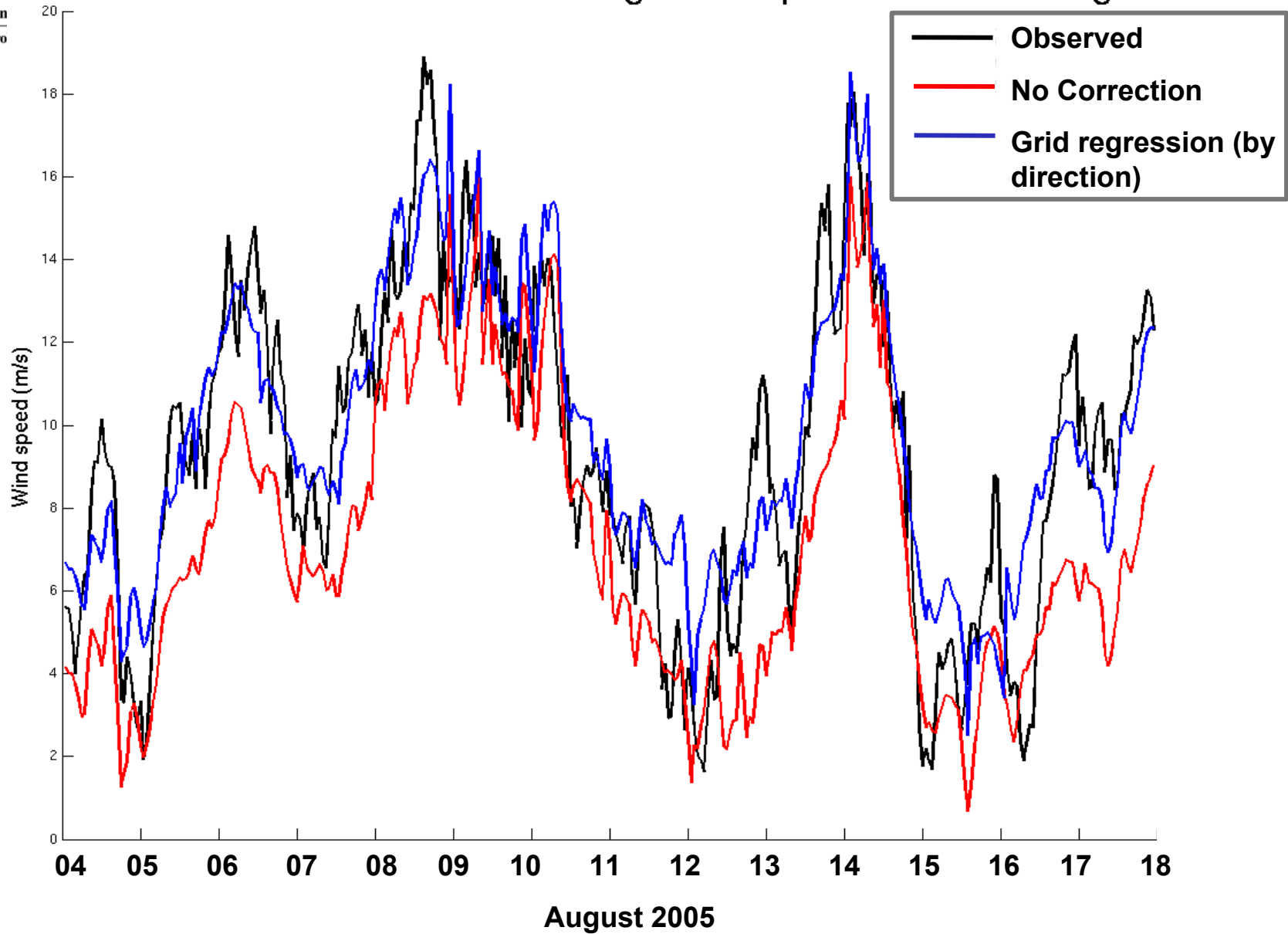



Forcing

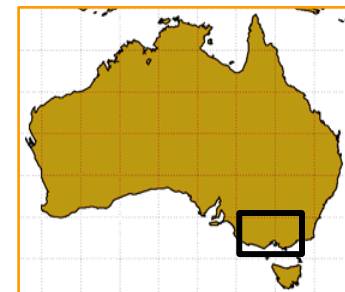
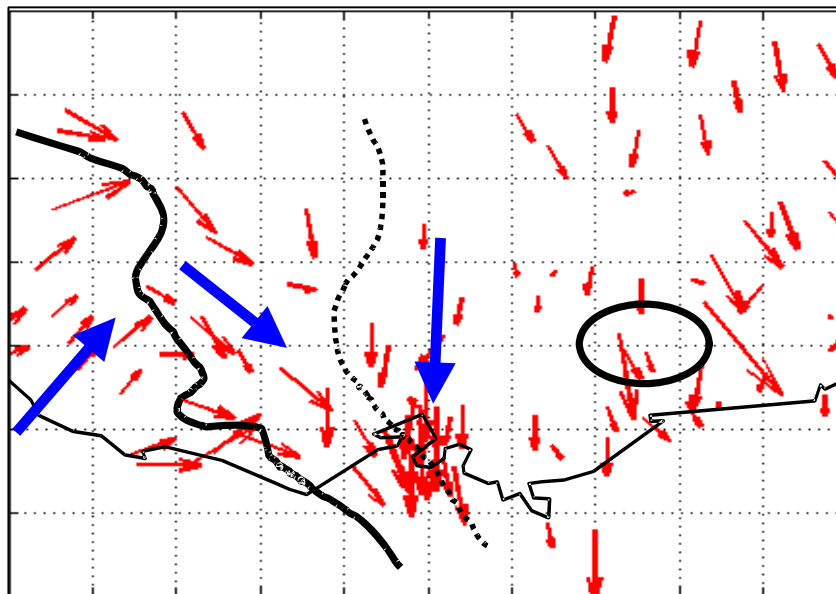

mesoLAPS

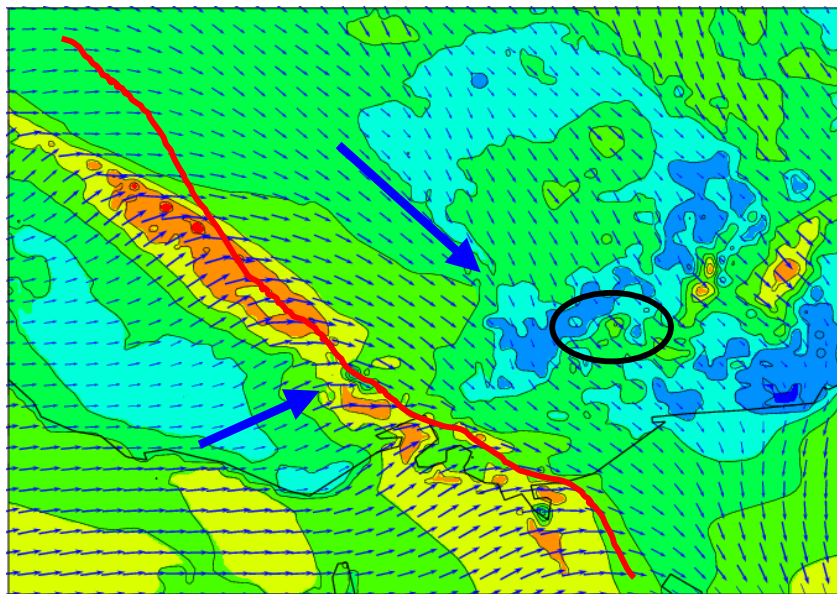

WLAPS

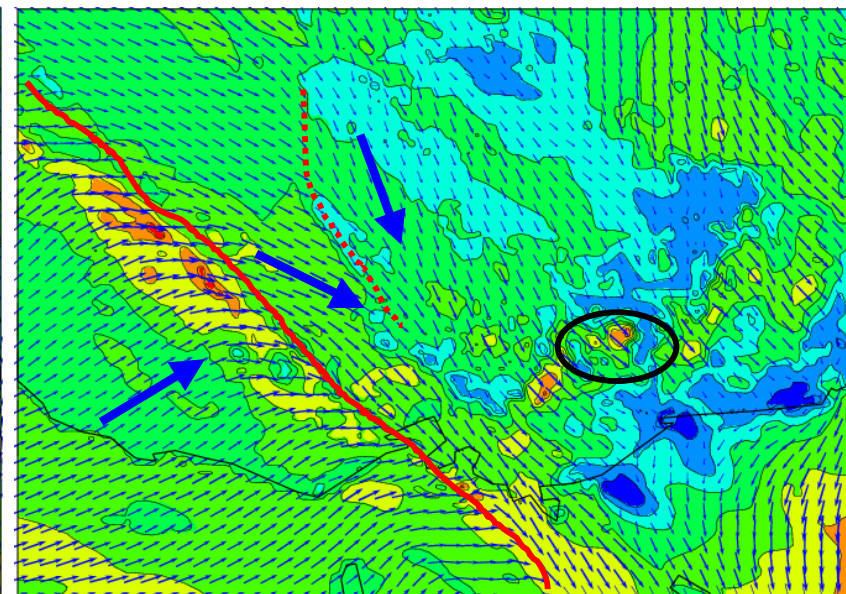



Vertical Motion at ~1500m (m/s)



mesoLAPS

WLAPS

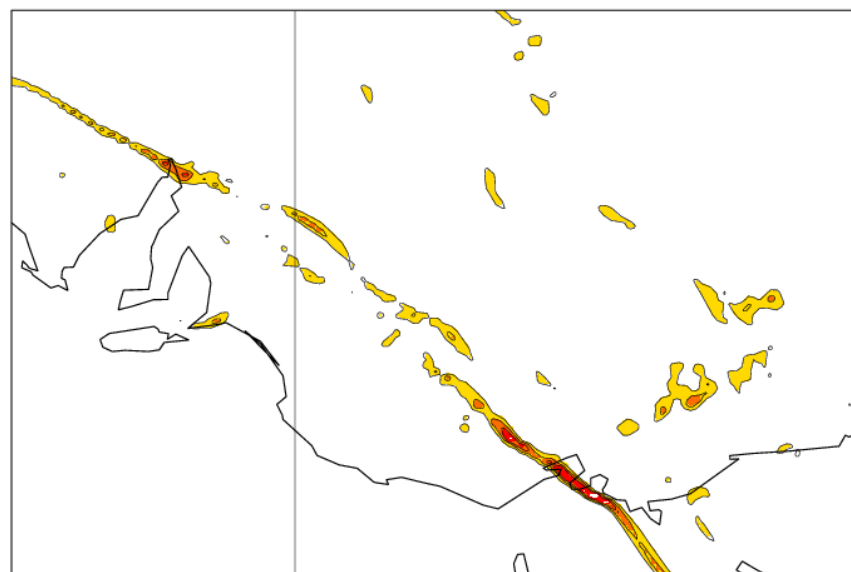
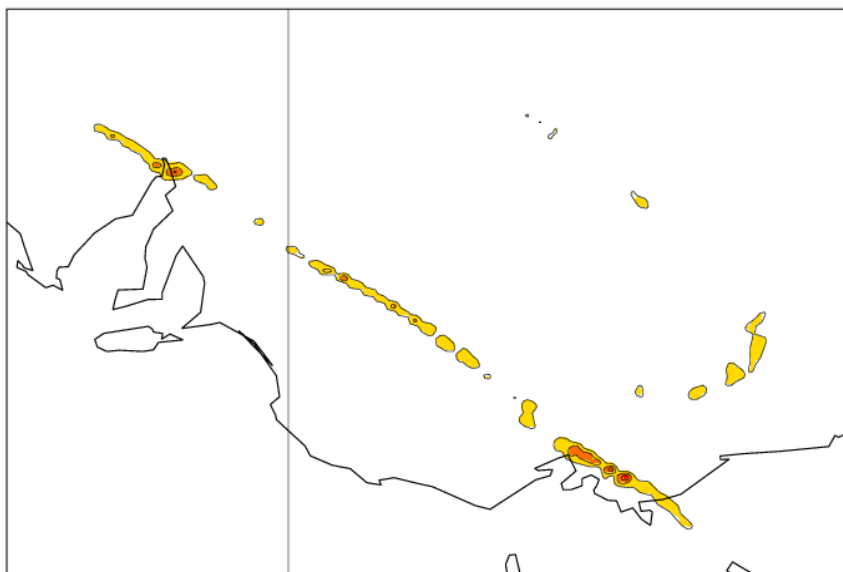



- WLAPS forecasts features at a higher resolution and with better timing than mesoLAPS
- WLAPS hub-height forecasts are strongly amenable to bias correction, showing that a large proportion of the error is systematic
- WLAPS has also been shown to capture the overall state of the atmosphere in complex weather systems better than mesoLAPS.
- It is yet to be determined how much of this improved performance is due to the assimilation of ATOVS by WLAPS itself, and how much by the impact of improved ATOVS assimilation in the nesting GASP and LAPS models. A study to investigate the impact of withholding ATOVS data from WLAPS is underway.



The Future

- **L60 GASP to become operational 4Q 2006**
- **L61 LAPS to become operational 4Q 2006/1Q 2007**
- **L61 WLAPS to become operational 2007**

- **2007 and beyond: ACCESS (Australian Community Climate and Earth System Simulator)**
- **Collaboration between the Bureau of Meteorology, CSIRO and universities**
- **ACCESS to import the Met Office atmospheric model HadGAM1 to provide the initial atmospheric model for ACCESS**
- **The Met Office 4DVAR scheme to be imported to form the atmospheric data assimilation module in ACCESS**