



The 2nd Generation of Chinese Polar-orbiting Satellite-Fengyun-3 Series: Status Report

Jun Yang, Chaohua Dong, Peng Zhang and Gang Ma
Chinese National Satellite Meteorological Center

May 12, 2008

FY3A Launch Date: May 28, 2008



Testing to instruments of FY3 will be performed 6 months after its launch

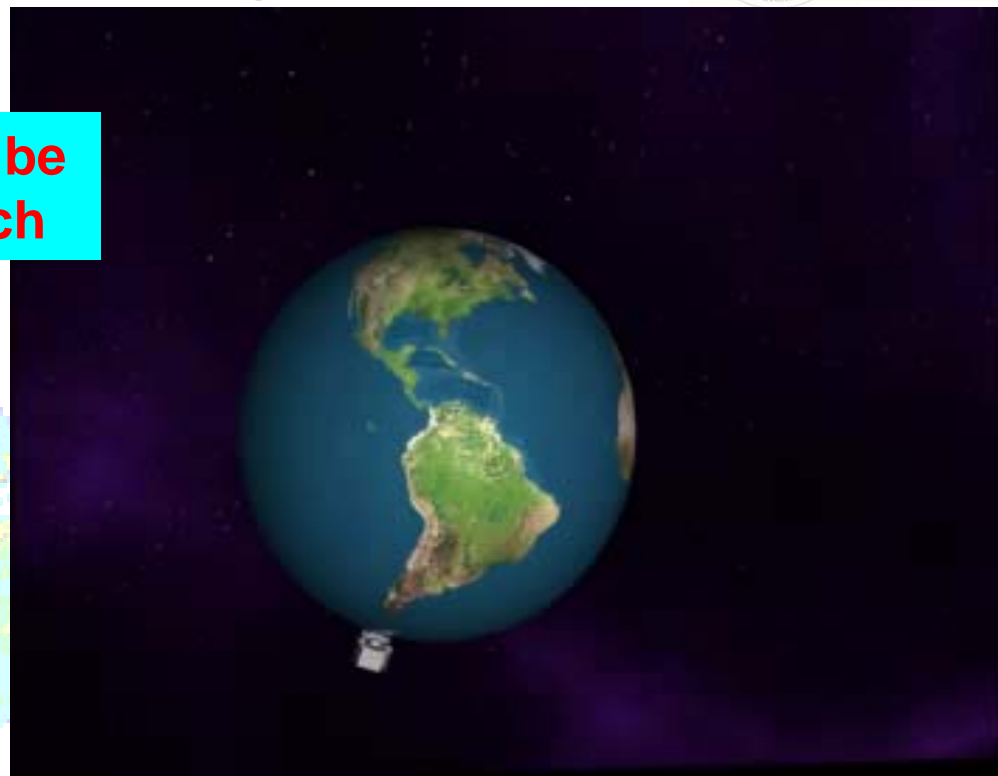
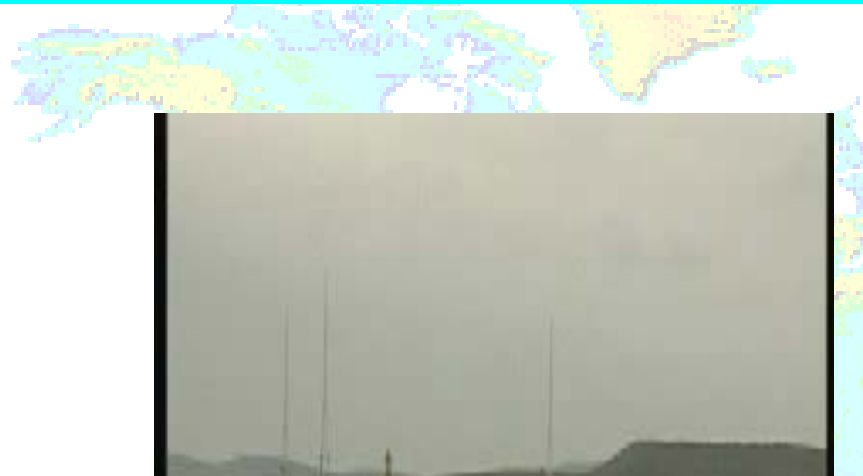

Data processing package will be free and will be released according to its schedule

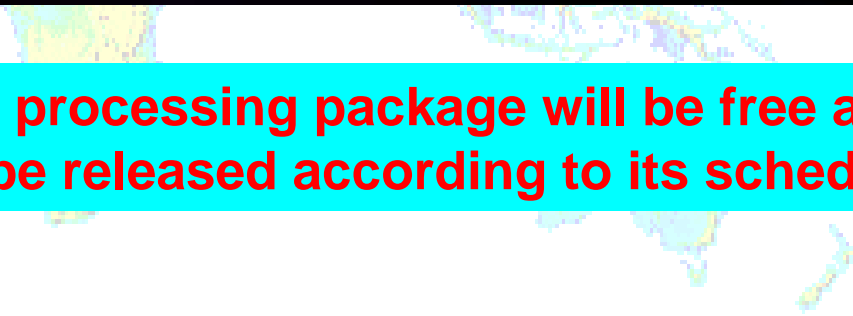

Outline



- **FY3 Series**

- **Main instrument Specifications**

- **Data Broadcasting**

- **Data Processing**

- **Applications**

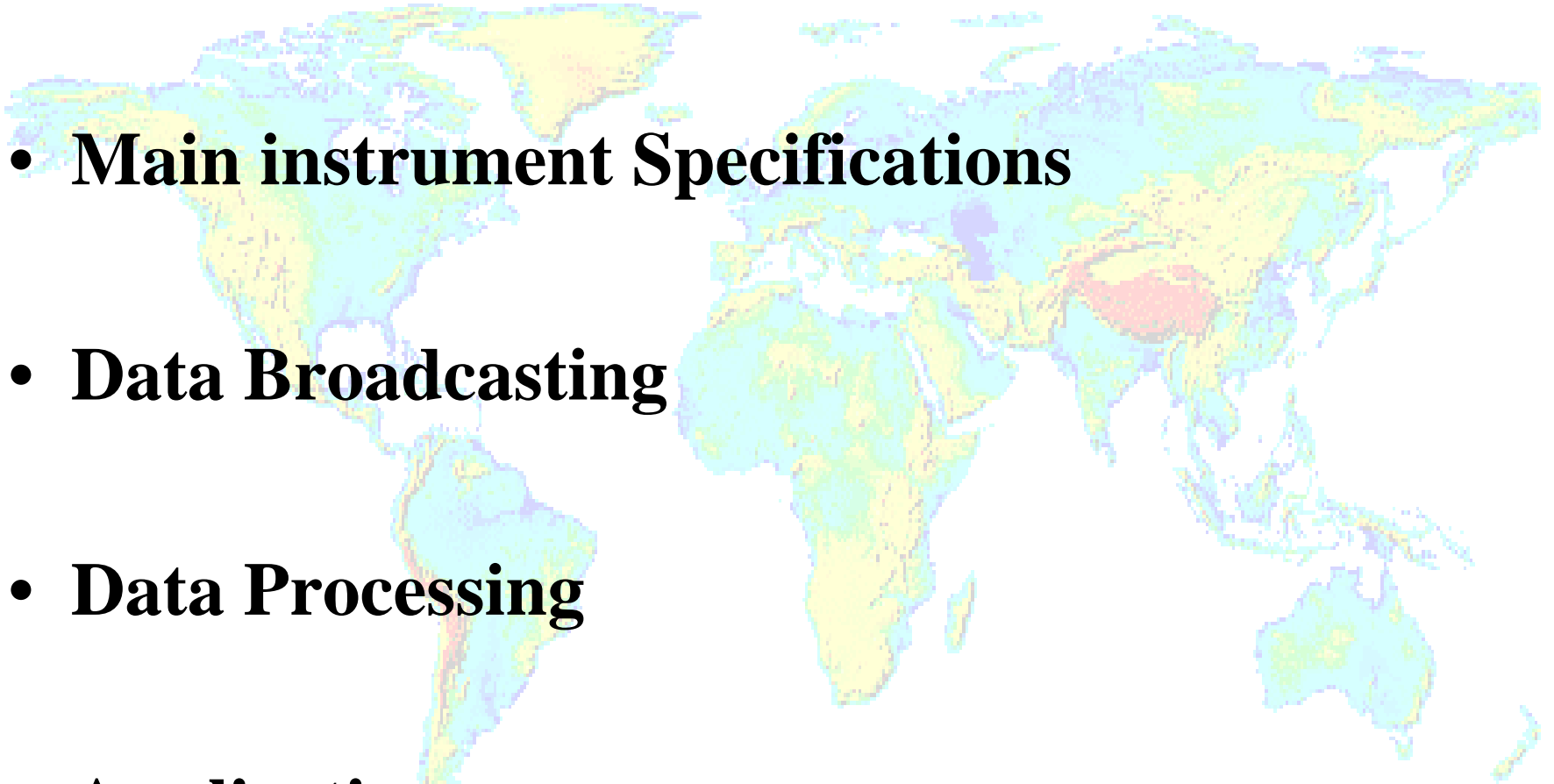



FY3 Series

The 2nd generation of polar satellites



✓ Purpose of FY-3A/B

- Experimental satellites
- Products demonstration
- Possible operational applications

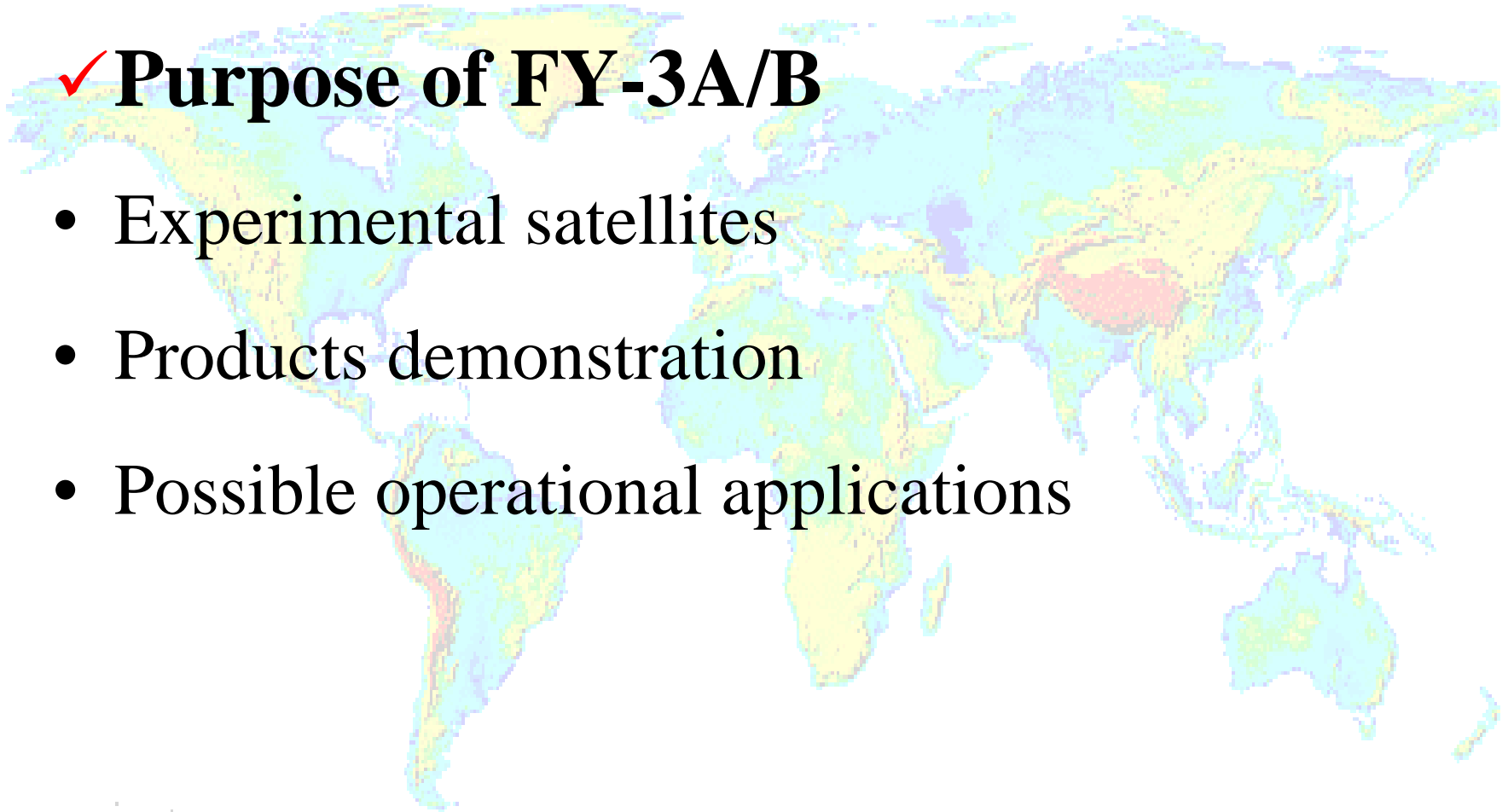



Two phases of FY-3 series

- Experimental Phase (2007-2009 in flight):
2 satellites with improved sounding capabilities
 - FY-3A Launch scheduled in May 2008
 - FY-3B launched scheduled in Early 2009
- Operational Phase (flight after 2009):
Satellites Constellation is planned with expanded sounding and imaging capabilities



FY-3 Operational Constellation

Considerations

- ✓ Instruments on FY-3A/B will be improved and refined for FY-3 Op satellites
- ✓ Two polar satellites in operation (one in the **AM** and one in the **PM** orbit, **payload will be different for AM/PM satellites**, time slots could be coordinated through WMO)
- ✓ **One low inclination orbit satellite is planning**, mainly for **precipitation measurement** (mainly **Radar, Passive Microwave measurement**). **Details is still in discussion**



Main instrument Specifications



Main specifications of FY-3A

- ✓ Orbit: Sun-synchronous polar-orbiting
- ✓ Orbit altitude: **836** km
- ✓ Inclination=**98.728** degree
- ✓ Eccentricity: better than **0.0034**
- ✓ Nodal crossing time: **10:10-10:20 am** (LST, FY-3B could be at afternoon orbit)
- ✓ Orbit drifting: < **10** minutes (within 2 years)

Main specifications of FY-3A (cont.)

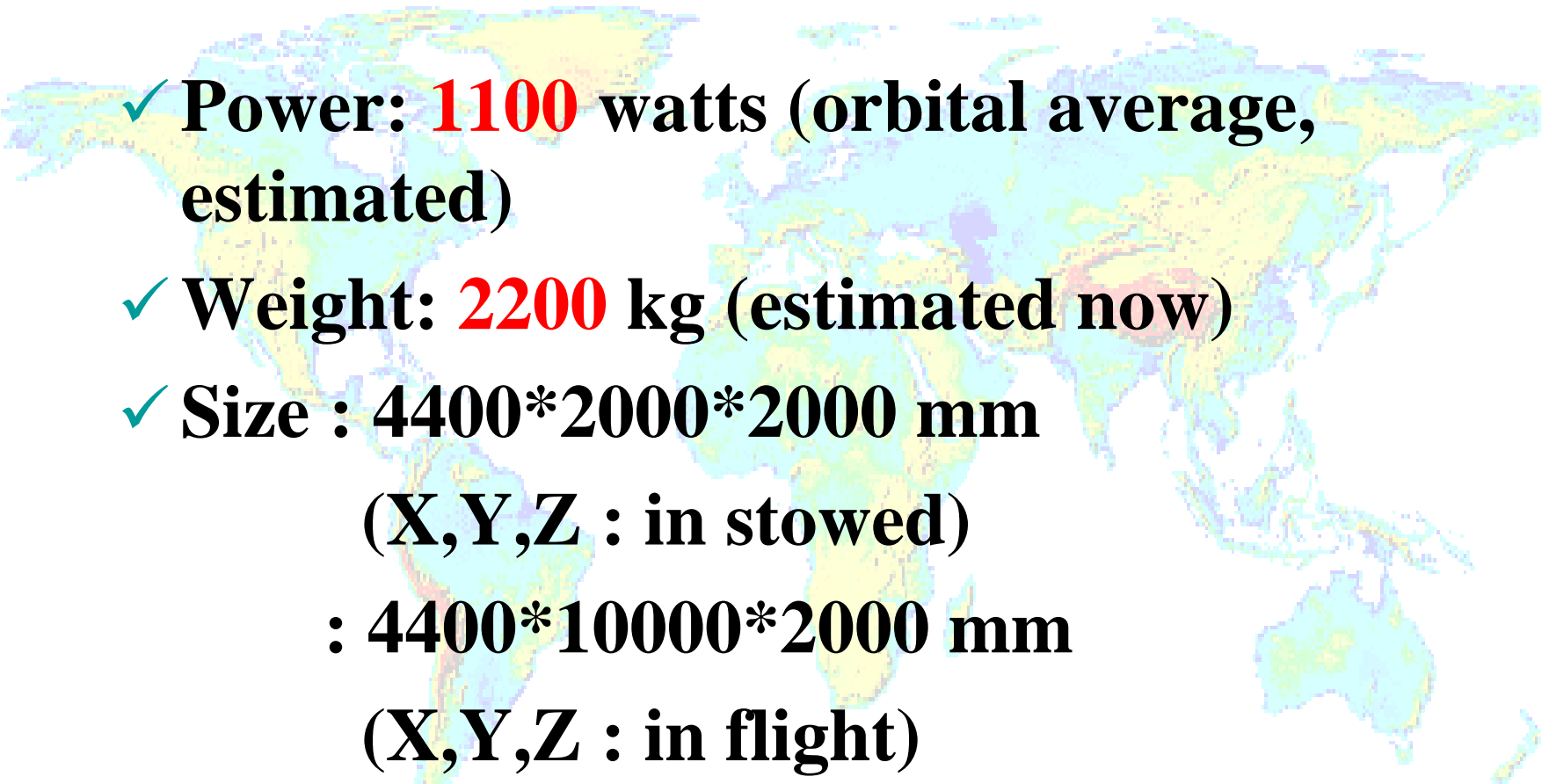
- 
- ✓ Power: **1100** watts (orbital average, estimated)
 - ✓ Weight: **2200** kg (estimated now)
 - ✓ Size : **4400*2000*2000** mm
(X,Y,Z : in stowed)
: **4400*10000*2000** mm
(X,Y,Z : in flight)
 - ✓ Design life: \geq **3** years

Main Instruments on FY-3



(1) Sounding Mission(5 instruments)

- ✓ Infrared Atmospheric Sounder (**IRAS**)
- ✓ MicroWave atmospheric Temperature Sounder (**MWTS, MSU like**)
- ✓ MicroWave atmospheric Humidity Sounder (**MWHS, AMSU-B like, onboard FY-3A/B.**)
- ✓ Multichannel Atmospheric Infrared Sounder (**MAIRS, OP. phase**)
- ✓ Solar Backscatter Ultraviolet Sounder
Ozone Unit (**SBUS/TOU**)

VASS:
Vertical Atmospheric
Sounding System

Main Instruments on FY-3

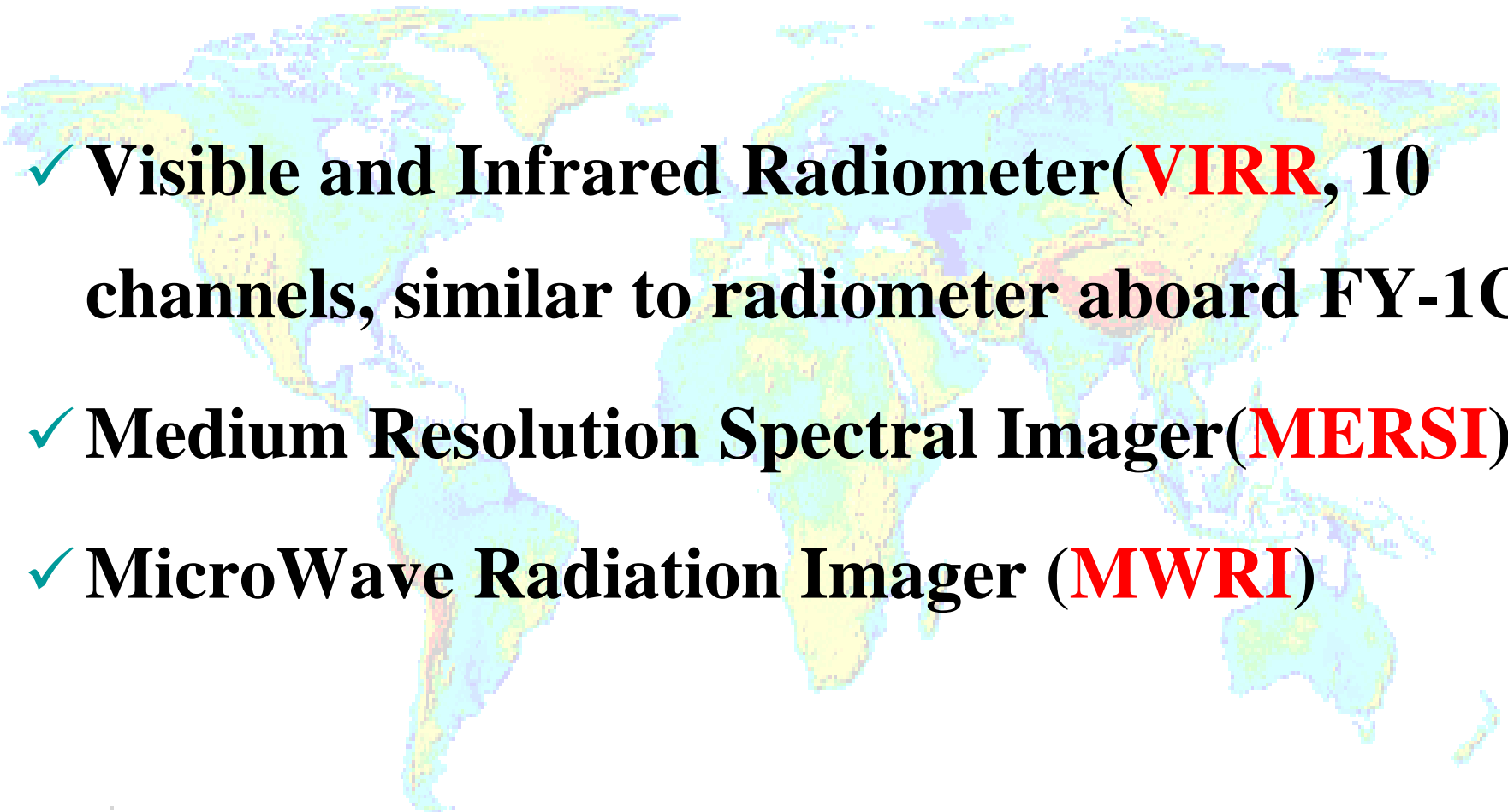

(2) Imaging Mission(3 instruments)

- 
- ✓ Visible and Infrared Radiometer(**VIRR**, 10 channels, similar to radiometer aboard FY-1C)
 - ✓ Medium Resolution Spectral Imager(**MERSI**)
 - ✓ MicroWave Radiation Imager (**MWRI**)

Main Instruments on FY-3



(3) Complementary Mission

- 
- ✓ **Earth Radiation Budget Unit (ERBU)**
 - ✓ **Space Environment Monitor (SEM)**
 - ✓ **Data Collection System (DCS)**

IRAS Channels Characteristics



Channel No.	Central wavenumber (cm ⁻¹)	Central wavelength (μm)	bandwidth (cm ⁻¹)	Main absorbers	Maximum temperature (K)	NEΔN (mW/m ² -sr-cm ⁻¹)	Maximum contributed layer (hPa)
1	669	14.95	3	CO ₂	280	4.00	30
2	680	14.71	10	CO ₂	265	0.80	60
3	690	14.49	12	CO ₂	250	0.60	100
4	703	14.22	16	CO ₂	260	0.35	400
5	716	13.97	16	CO ₂	275	0.32	600
6	733	13.84	16	CO ₂ /H ₂ O	290	0.36	800
7	749	13.35	16	CO ₂ /H ₂ O	300	0.30	900
8	802	12.47	30	Window	330	0.20	Surface
9	900	11.11	35	Window	330	0.15	Surface
10	1030	9.71	25	O ₃	280	0.20	25
11	1345	7.43	50	H ₂ O	330	0.23	800
12	1365	7.33	40	H ₂ O	285	0.30	700
13	1533	6.52	55	H ₂ O	275	0.30	500
14	2188	4.57	23	N ₂ O	310	0.009*	1000
15	2210	4.52	23	N ₂ O	290	0.004*	950
16	2235	4.47	23	CO ₂ /N ₂ O	280	0.006*	700
17	2245	4.45	23	CO ₂ /N ₂ O	266	0.006*	400
18	2388	4.19	25	CO ₂	320	0.003*	Atmosphere
19	2515	3.98	35	Window	340	0.003*	Surface
20	2660	3.76	100	Window	340	0.002	Surface
21	14500	0.69	1000	Window	100%A	0.10%A	Cloud
22	11299	0.885	385	Window	100%A	0.10%A	Surface
23	10638	0.94	550	H ₂ O	100%A	0.10%A	Surface
24	10638	0.94	200	H ₂ O	100%A	0.10%A	Surface
25	8065	1.24	650	H ₂ O	100%A	0.10%A	Surface
26	6098	1.64	450	H ₂ O	100%A	0.10%A	Surface

MWTS Channel Characteristics



Channel No.	Central Frequency (GHz)	Main Absorber	Band Width (MHz)	NE Δ T (k)	Antenna Beam Efficiency (%)	Dynamic Range (K)
1	50.30	Window	220	0.3	□90	3-340
2	53.74	O ₂	220	0.3	□90	3-340
3	54.96	O ₂	220	0.3	□90	3-340
4	57.95	O ₂	220	0.3	□90	3-340

MWHS Channel Characteristics



Channel No.	Central Frequency (GHz)	Main Absorber	Band Width (MHz)	NE Δ T (k)	Antenna Beam Efficiency (%)	Dynamic Range (K)
1	150(V)	Window	1000	0.9	$\geq 95\%$	3-340
2	150(H)	Window	1000	0.9	$\geq 95\%$	3-340
3	183.31 \pm 1	H ₂ O	500	1.1	$\geq 95\%$	3-340
4	183.31 \pm 3	H ₂ O	1000	0.9	$\geq 95\%$	3-340
5	183.31 \pm 7	H ₂ O	2000	0.9	$\geq 95\%$	3-340

MWTS-MicroWave Temperature Sounder

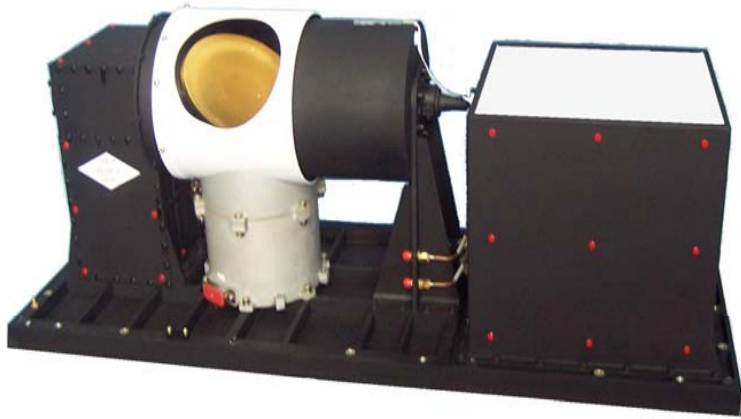

IRAS-InfraRed Atmospheric Sounder

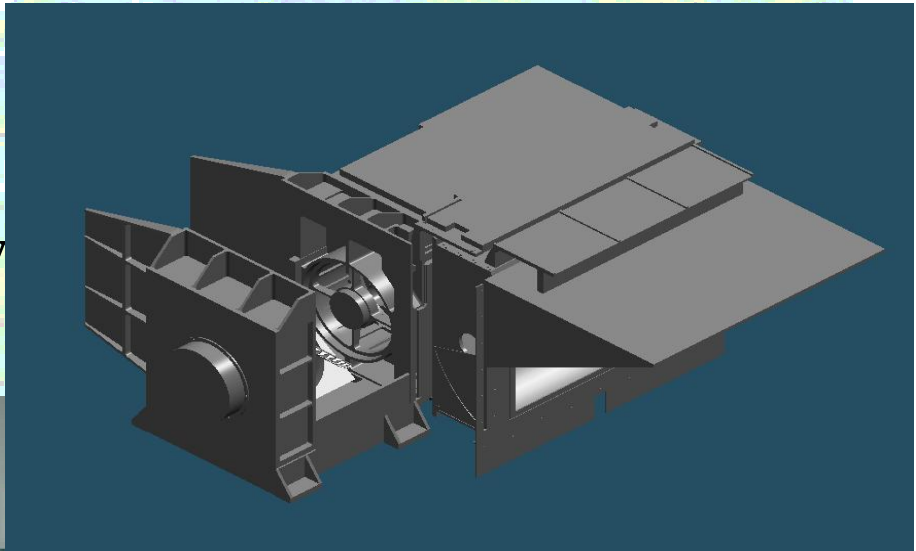

MWHS-MicroWave Humidity Sounder





Data Broadcasting

Data processing package can process other satellite data from Europe and US

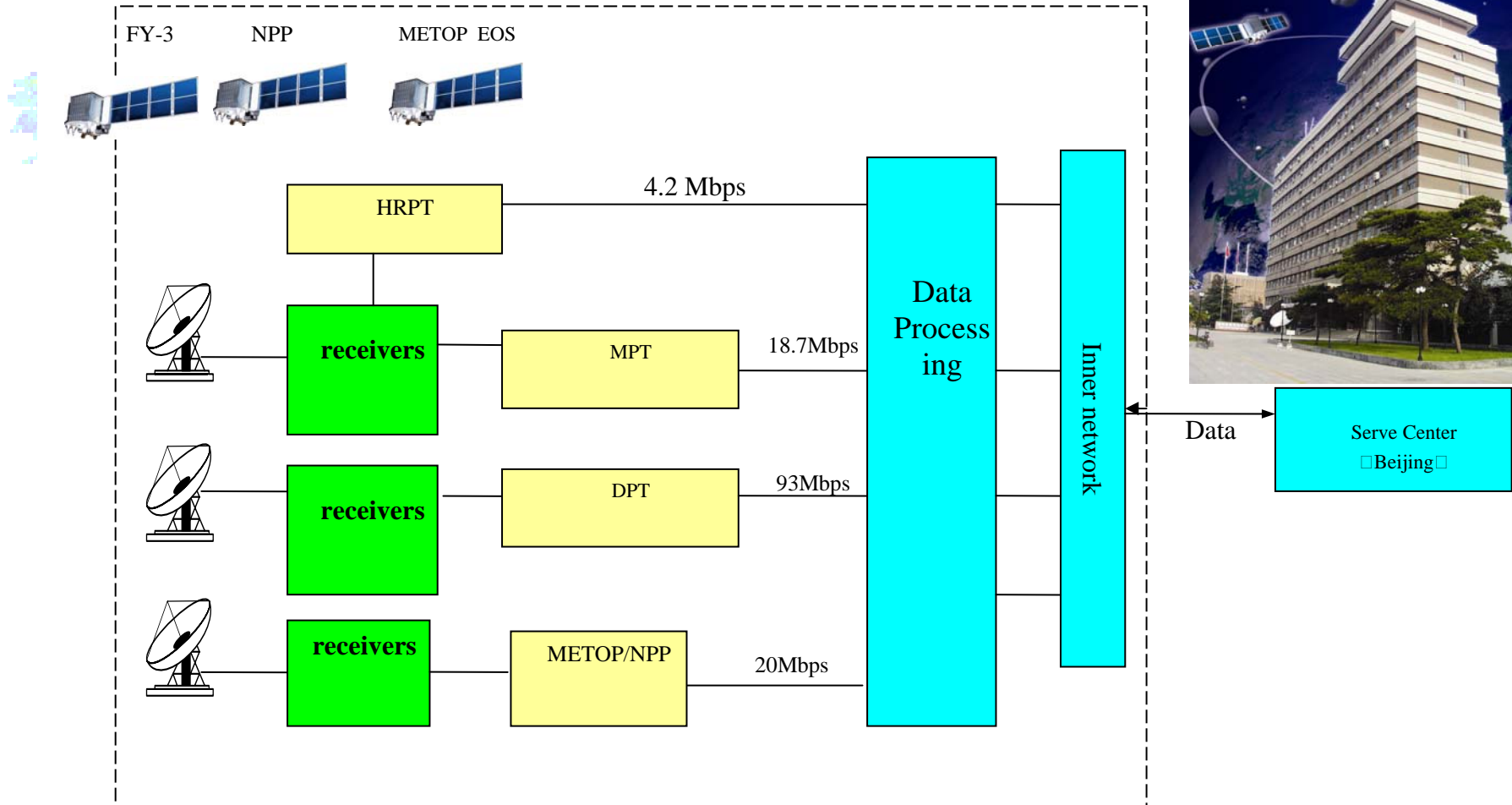

Serve Center
□Beijing□

Data types: **HRPT** format

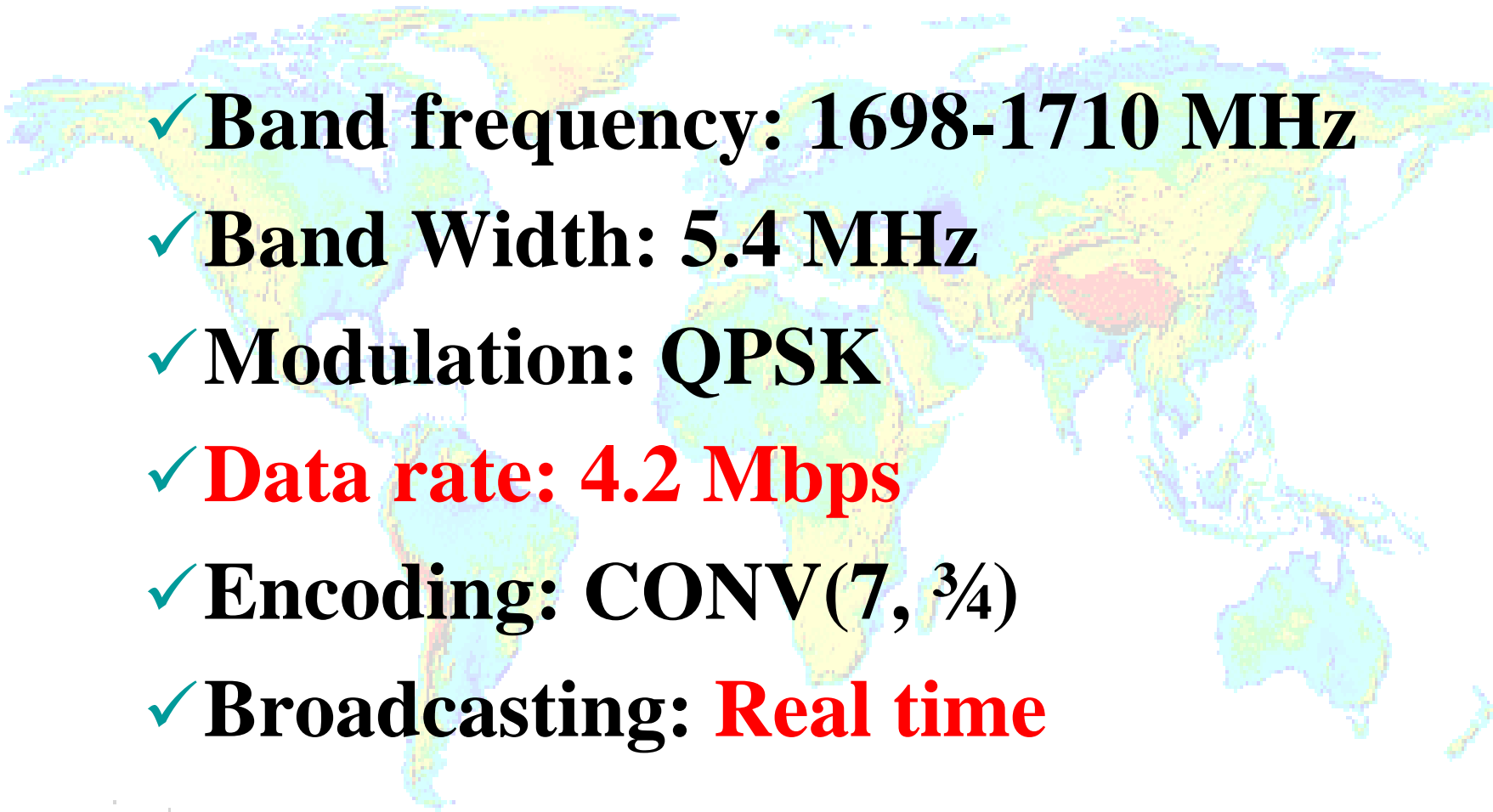
- 
- ✓ **Band frequency: 1698-1710 MHz**
 - ✓ **Band Width: 5.4 MHz**
 - ✓ **Modulation: QPSK**
 - ✓ **Data rate: 4.2 Mbps**
 - ✓ **Encoding: CONV(7, $\frac{3}{4}$)**
 - ✓ **Broadcasting: Real time**



Data types: **DPT** format

- ✓ **DPT=Delayed Picture Transmission**
- ✓ **Band frequency: 8025-8215/8215-8140 MHz**
- ✓ **Band Width: 140 MHz**
- ✓ **Modulation: QPSK**
- ✓ **Data rate: 110 Mbps**
- ✓ **Encoding: CONV(7, $\frac{3}{4}$)**
- ✓ **Broadcasting: **Within China capture area****

Data types: **MPT** format

- ✓ **MPT=Mission Picture Transmission**
- ✓ **Band frequency: 7750-7850 MHz**
- ✓ **Band Width: 25 MHz**
- ✓ **Modulation: QPSK**
- ✓ **Data rate: 20 Mbps**
- ✓ **Encoding: CONV(7, $\frac{3}{4}$)**
- ✓ **Broadcasting: program controlled**

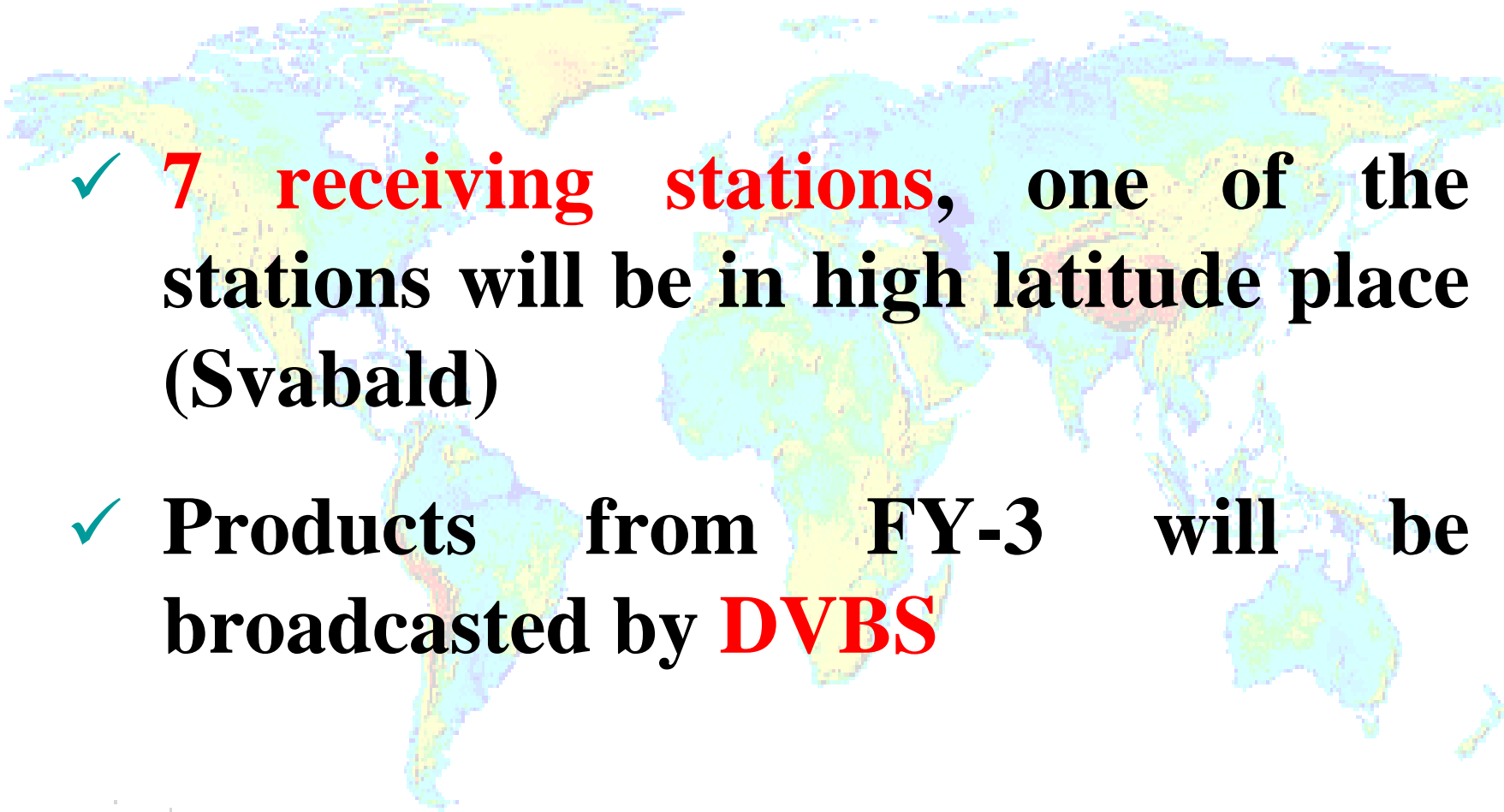
- 
- ✓ **7 receiving stations**, one of the stations will be in high latitude place (Svabald)
 - ✓ Products from **FY-3** will be broadcasted by **DVBS**

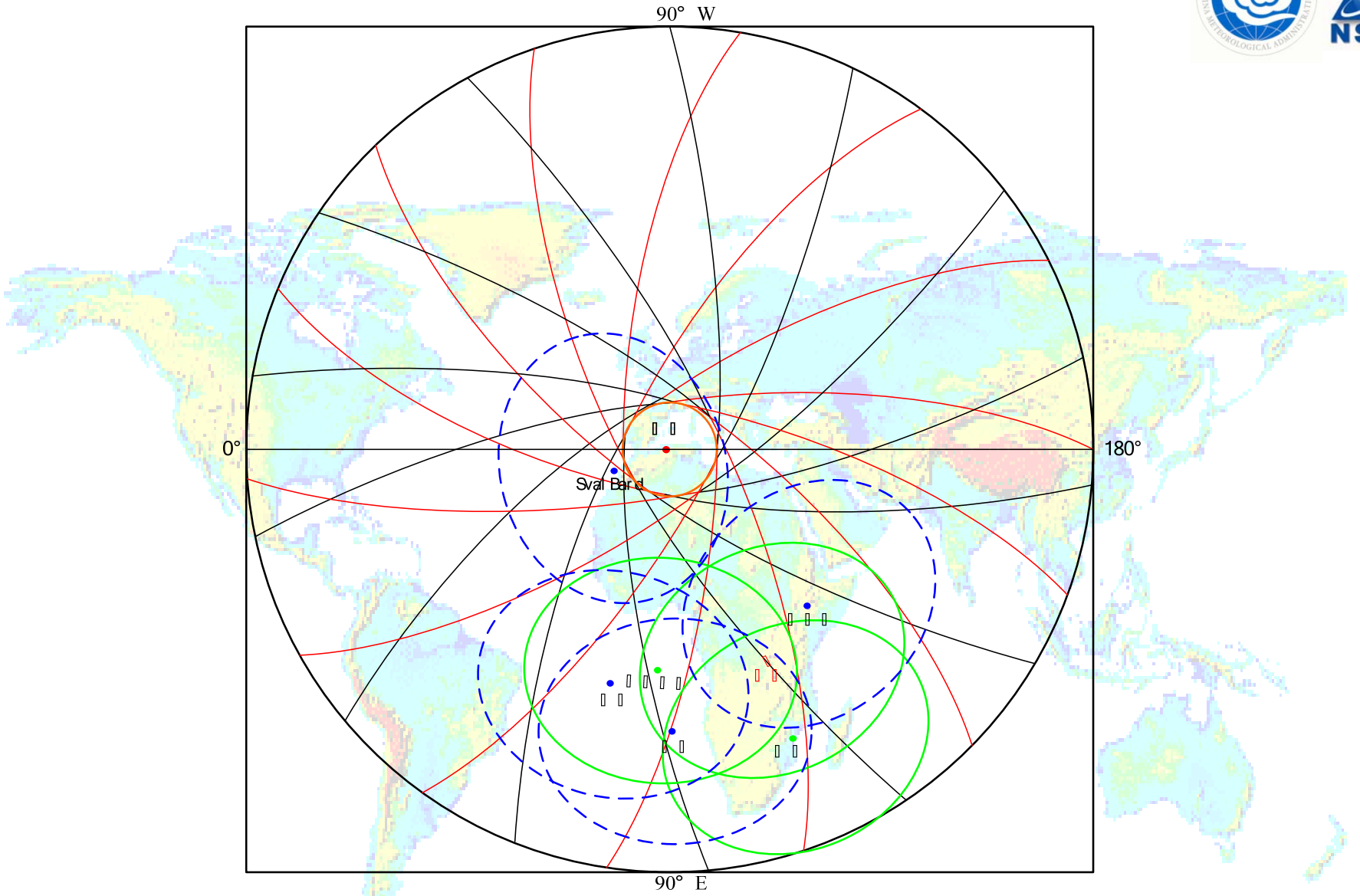

90° W

0°

180°

Svalbard

90° E

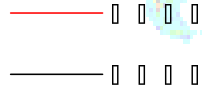

Data transmission to Beijing and then re-transmit (DVBS)

This technology will be used in FY-3 data re-transmission



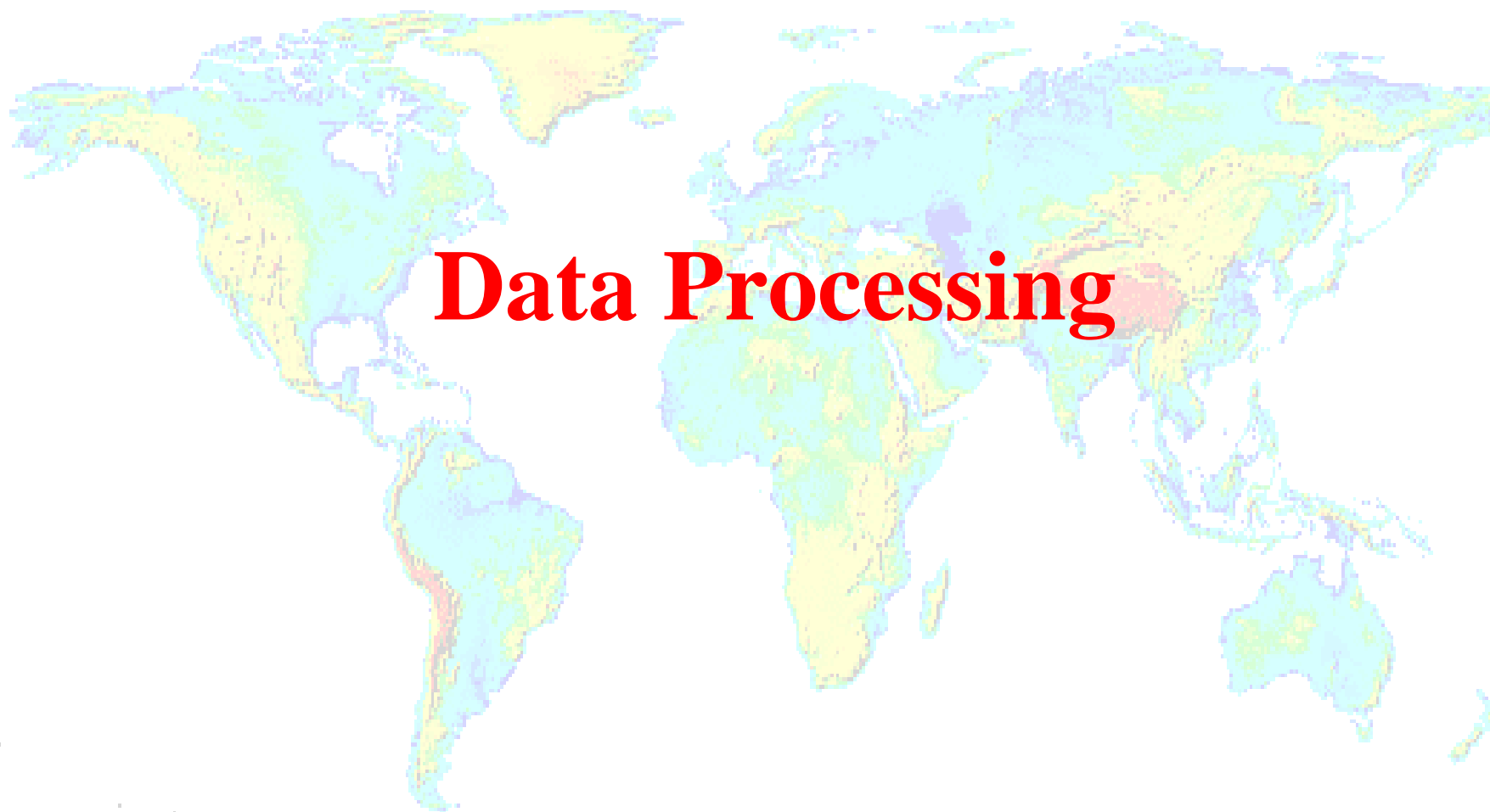

Data Processing

FY-3 Operational Products

(Atmospheric and Cloud) (1/4)



No.	The name of product	Resolution km	Coverage	Accuracy
1	Cloud Mask	Lw resolution	Granule	5%-20%
2	Cloud Top Temperature	5 km	Granule	0.5-2.0K
3	Cloud Top Height	5 km	Granule	50hpa
4	Cloud Optical Thickness	5 Km	global	5%-20%
5	Cloud Type	5 Km	global	5%-20%
6	Cloud Cover(total amount, high cloud)	5 Km, 10 Km	global	5%-20%
7	Outgoing Long-wave Radiation at TOA	5 Km 50Km 17 Km	global	3-8 W/
8	Aerosol over Ocean	1Km 10 Km	Ocean	15%-30%
9	Fog Detection	1 Km	Granule	RMS < 0.25
10	Total Precipitable Water	1 Km 5 Km 50 Km 27X45	land Ocean	15%-25% 10%-20%

FY-3 Operational Products

(Atmospheric and Cloud) (2/4)



No.	The name of product	Resolution km	Coverage	Accuracy
11	Precipitation Rate at the ground	18X30 km	global	30%
12	Atmospheric Temperature Profile 1000-10hPa	50km	global	1.5-2.5K
13	Humidity Profile 1000-300hPa	50km	global	15%-25%
14	Geopotential Height 1000-10hPa	50km	global	TBD
15	Atmospheric Stability Index	50km	global	TBD
16	Total Ozone	50km 17km	global	8-15%
17	Ozone Profile	200 Km	global	8-15%
18	Flux at at TOA from ERM scanner	35Km	Orbit/Regional/global	LW:10Wm ⁻² SW:30Wm ⁻²
19	Flux at at TOA from ERM non scanner	120°	Orbit	LW:10Wm ⁻² SW:30Wm ⁻²

FY-3 Operational Products

(Land and Sea Surface) (3/4)



No.	The name of product	Resolution	Coverage	Accuracy
1	Vegetation Index Normalized Differential Vegetation Index	250m 1Km	Global	5%-10%
2	Land Cover (Vegetation Type)	250m 1 Km	Global	15%-20%
3	Snow Cover	1Km 5Km	Global	10%-20%
4	Land Surface Reflectivity	250m 1Km	Global	TBD
5	Land Surface Temperature	1 25 50X85km	Global	1.0-2.0K
6	Flooding Index	50X85 25 km	Global	TBD
7	Global Fire Area	1km	Global	5%
8	Sea Surface Temperature	1 5 50 Km	Global Ocean	1.0-1.5K
9	Ocean Color/Chlorophyll	1 Km 10 Km	Global Ocean	15%-20%
10	Sea-Ice cover	250m 1km	Global Ocean	5%-15%



Applications



Eumetsat SAF

The network of Satellite Application Facilities (SAFs) in Europe

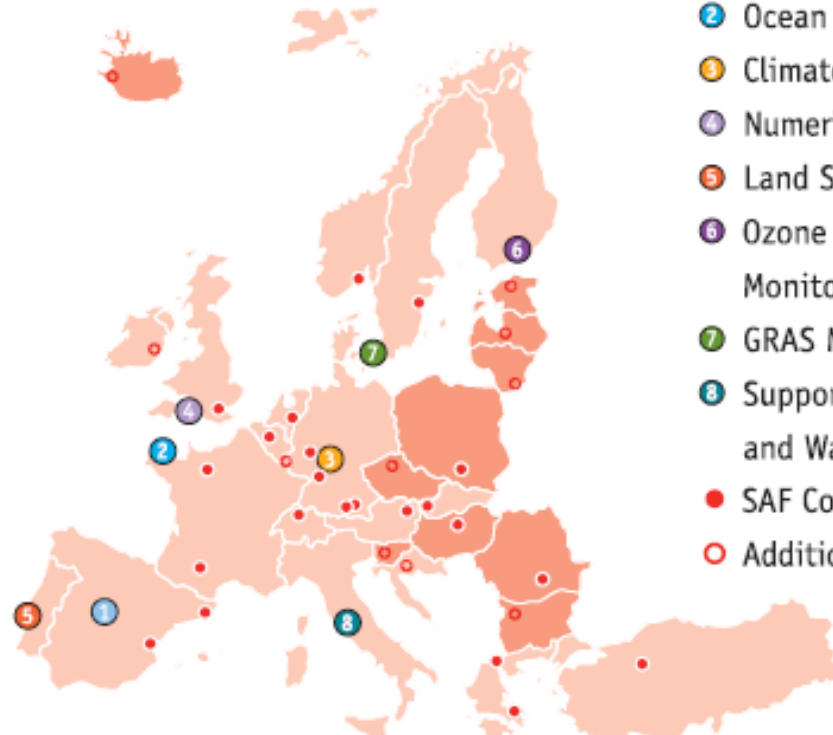

- ① Support to Nowcasting and Very Short Range Forecasting
- ② Ocean and Sea Ice
- ③ Climate Monitoring
- ④ Numerical Weather Prediction
- ⑤ Land Surface Analysis
- ⑥ Ozone and Atmospheric Chemistry Monitoring
- ⑦ GRAS Meteorology
- ⑧ Support to Operational Hydrology and Water Management
- SAF Consortium Member
- Additional Met Service Users

Experiences from EUMETSAT SAF indicate: it is an efficient way to send satellite data directly to the ministrant department!

Experience has demonstrated that one of the most effective ways to improve the utilisation of satellite data is to bring the satellite data to centres of excellence that focus on serving a particular application. The presence of application-oriented scientists with well defined objectives provides a strong motivation to use the available data in the most effective way and helps avoid a specialisation in the satellite technology rather than in real-world environmental challenges.

Possible application of FY3

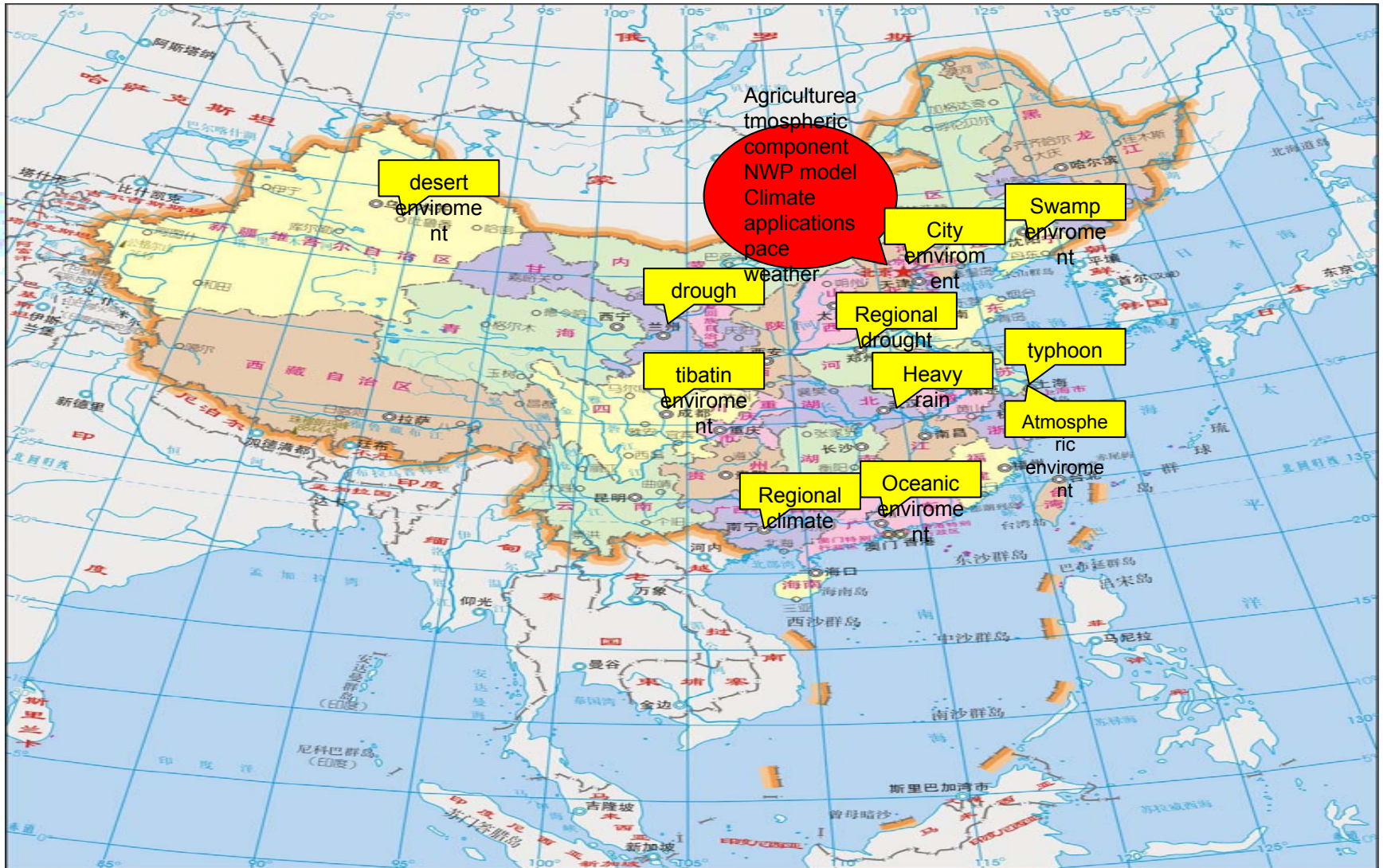

Based on NSMC, NMC and other regional operational departments and research groups

Application Cover 9 Fileds of GEOSS

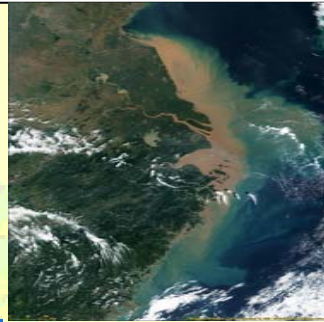
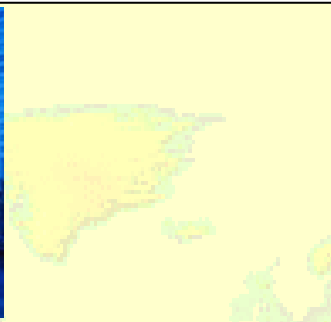

Disaster
from Natural
& Factitious



Water
Source



Terrestrial &
Oceanic
biogeocenose

Human Health
& Welfare



Energy
Source

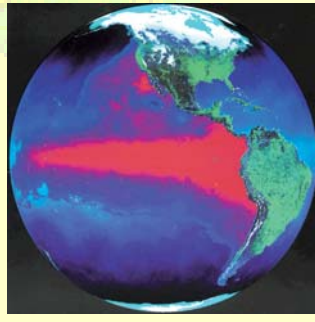

Agriculture
& Hugniness



Weather
Prediction

Climate

Biology &
its
diversity



..... *Stop Here*

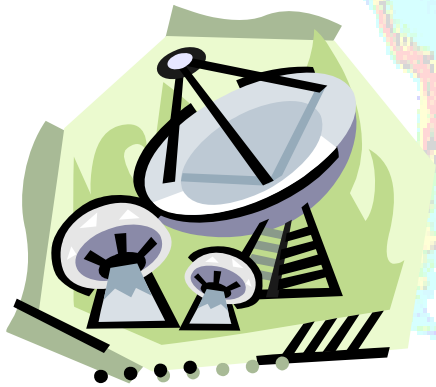
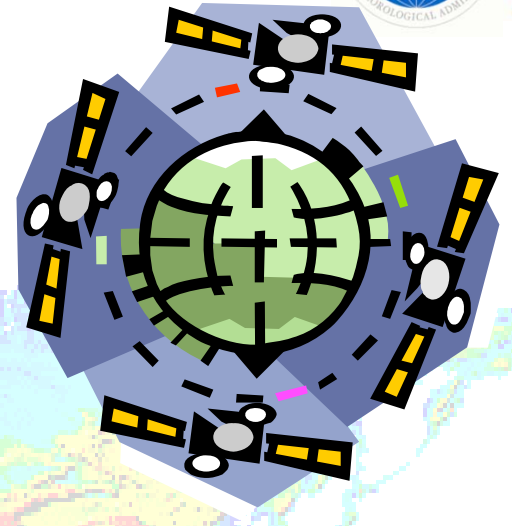

Thank you